

Secrets & Science of Home Energy Efficiency

Welcome

Betty Hall / Energy Information Specialist

(907) 330-8166 or outside of Anchorage (800)478-4636

bhall@ahfc.us

Disclaimer: The information and materials provided by the Alaska Housing Finance Corporation are not comprehensive and do not necessarily constitute an endorsement or approval, but are intended to provide a starting point for research and information. AHFC does not endorse or sell any products.

What we'll cover:

- The Value of an Energy Rating
- Understanding Energy Improvements
- Lighting, Appliances & Tips to Save Money
- The Research Information Center – Resources
- AHFC's Energy Programs

The Value of an Energy Rating

Energy Rating & Energy Efficiency Improvement Options Report

Home Energy Rating Certificate



UNOFFICIAL

The Home Located At:

1234 Snow Filled Circle
Anchorage, Alaska

Has Been Energy-Rated As:

★ ★

Two Star

Overall Efficiency of Home

56.2 points

BEES Compliance

Fail

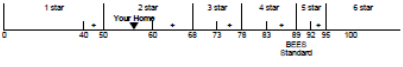

Amount of CO2 Produced by the Home

30,902 pounds per year

Projected Annual Energy Costs

\$5,770 per year

Breakdown of Heating Costs, \$ Per Year

Floor	\$353
Wall/Door	\$389
Window	\$14
Ceiling	\$237
Air/Vent	\$778
Htg System Loss	\$1,801
Hot Water	\$1,242

Client: Happy Homeowner Rater: Rater A, Raters R Us Date: 1/29/2014
 Rater's City: Anchorage, AK 99504 Contact: 907-330-9187, Notsooold@winter.us, FAX 907-330-6197
 ver. 2.3.2.1, library: 9/24/2013, file: Happy Homeowner.hmi2, Rating Type: BEES

I certify that this Rating is true and correct, to the best of my knowledge and belief: _____
 Rater Signature

Energy Efficiency Improvement Options

Property: energy efficiency
110 full throttle
Anchorage, AK 99517

House: Multi-Family, One Unit
Living Floor Area: 1,500 sq.ft
2-Car Attached Garage

Rater: AHFC Rater
AHFC
Boniface
Anchorage

ID: read a rating

Initial Rating: Two Star, 54.3 points
Additional Rating Points needed to reach higher Rating Levels:
 5.7 more points needed to reach 2+ Stars
 13.7 more points needed to reach 3 Stars
 19.7 more points needed to reach 3+ Stars
 23.7 more points needed to reach 4 Stars
 28.7 more points needed to reach 4+ Stars
 33.7 more points needed to reach 5 Stars
 37.7 more points needed to reach 5+ Stars

Fuel Prices used in this Analysis: Electricity = \$0.1242/kWh, Natural Gas = \$0.75/cf

The following are possible energy-saving improvements for your home.
Notes: The Rating points you receive for each improvement depend upon the other measures you install. In the report below, the points indicated for each measure assume that you install all prior measures on the list. The Break-Even cost is the *most* you could pay for the improvement and still have it be cost-effective based on energy savings over the life of the measure.

Improvement Description / Location	Annual Savings ¹	Break-Even Cost ²	Rating Points Gained ³	Rating, after all Improvements thru this one ⁴	Design Heat Loss, Btu/hr ⁵
Fill empty 2x12 cavity with R-38 blown-in dense-pack insulation . Location - Exposed Floor: garage floor	\$189	\$4,136	4.6	58.9 points 2 Stars Increase: 4.6 pts, 0 steps	52,572
Add R-19 fiberglass batts to masonry wall. Cost does not include studs or furring strips. Location - Below- (part or all) Grade Wall: crawl space	\$117	\$2,564	2.8	61.7 points 2+ Stars Increase: 7.4 pts, 1 step	49,760
Install Lexan magnetic storm window on interior Location - Window/Skylight: 2nd floor skylights	\$29	\$456	0.7	62.4 points 2+ Stars Increase: 8.1 pts, 1 step	49,053
Caulk and Seal so that Home Air Leakage is Reduced by 1500 CFM at 50 Pascals.	\$422	\$3,787	10.2	72.6 points 3 Stars Increase: 10.3 pts, 2 steps	38,391
Add R-5 insulating blanket to garage door Location - Garage Door: garage overhead door	\$35	\$441	0.8	73.4 points 3+ Stars Increase: 19.1 pts, 3 steps	37,536
Add R-21 blown cellulose insulation to attic with Standard Truss. Location - Ceiling w/ Attic: garage attic	\$32	\$698	0.8	74.2 points 3+ Stars Increase: 19.9 pts, 3 steps	36,795
Install R-14 rigid board insulation Location - Exposed Floor: House floor	\$73	\$1,596	1.8	76.0 points 3+ Stars Increase: 21.7 pts, 3 steps	35,092
Add R-21 blown cellulose insulation to attic with Standard Truss.	\$55	\$1,207	1.3	77.3 points 3+ Stars	33,795



You may choose to do as many improvements as you like, *be sure to look at the “Rating Points Gained” you receive for each listed improvement.*

Improvement Description / Location	Annual Savings ¹	Break-Even Cost ²	Rating Points Gained ³	Rating, after all Improvements thru this one ⁴	Design Heat Loss, Btu/hr ⁵
Fill empty 2x12 cavity with R-38 blown-in dense-pack insulation . Location - Exposed Floor: garage floor	\$189	\$4,136	4.6	58.9 points 2 Stars Increase: 4.6 pts, 0 steps	52,572
Add R-19 fiberglass batts to masonry wall. Cost does not include studs or furring strips. Location - Below- (part or all) Grade Wall: crawl space	\$117	\$2,564	2.8	61.7 points 2+ Stars Increase: 7.4 pts, 1 step	49,760
Install Lexan magnetic storm window on interior Location - Window/Skylight: 2nd floor skylights	\$29	\$456	0.7	62.4 points 2+ Stars Increase: 8.1 pts, 1 step	49,053
Caulk and Seal so that Home Air Leakage is Reduced by 1500 CFM at 50 Pascals.	\$422	\$3,787	10.2	72.6 points 3 Stars Increase: 18.3 pts, 2 steps	38,391

Points	Rating
0-39	1 Star
40-49	1 Star +
50-59	2 Star
60-67	2 Star +
68-72	3 Star
73-77	3 Star +
78-82	4 Star
83-88	4 Star +
89-91	5 Star
92-94	5 Star +
95-100	6 Star

A red bracket connects the '2 Star' and '2 Star +' rows, with the text '1 step' written to the right of the bracket.

- ❑ *For example:* A home receiving 50-59 points would be a 2 Star home. If the home increased in efficiency to total 60-67 points, it would be a 2 Star Plus home.
- ❑ Therefore, the home moved one step on the star rating level. *
- ❑ A minimum of 5 points and at least one step are required for an interest rate reduction on an AHFC loan.

About AkWarm Energy Rating Software

- Energy raters do not give points: the rating software calculates them.
 - The rating software calculates efficiency by taking into account all parts of the house.
 - Rating points & improvements vary from house to house, as each one is different.
 - The rating software has been tested and approved by U.S. Department of Energy for the Weatherization Assistance Program.
-

Home Energy Rating Certificate

UNOFFICIAL



The Home Located At:
1234 Snow Filled Circle
Anchorage, Alaska

Has Been Energy-Rated As:
★ ★
Two Star

Overall Efficiency of Home
56.2 points

BEES Compliance
Fail

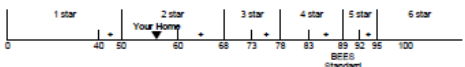

Amount of CO2 Produced by the Home
30,902 pounds per year

Projected Annual Energy Costs
\$5,770 per year

Breakdown of Heating Costs, \$ Per Year

Floor	\$353
Wall/Door	\$389
Window	\$14
Ceiling	\$237
Air/Vent	\$778
Htg System Loss	\$1,801
Hot Water	\$1,242

Client: Happy Homeowner **Rater:** Rater A, Raters R Us **Date:** 1/28/2014
Rater's City: Anchorage, AK 99504 **Contact:** 907 330-9187, Notsocold@winter.us, FAX 907 330-8197
 ver. 2.3.2.1, library: 9/24/2013, file: Happy Homeowner.hm2, Rating Type: BEES

I certify that this Rating is true and correct, to the best of my knowledge and belief: _____
 Rater Signature

Energy Rating Certificate

Shows star rating, points & energy costs of home.



Energy Cost and Features Report

Property: Happy Homeowner
1234 Snow Filled Circle
Anchorage, Alaska

Rater: Rater A
Raters R Us
4400 Boniface Parkway
Anchorage, AK 99504

House: Single Family
Living Floor Area: 1,264 square feet
No Attached Garage

Rating: BEES

Envelope Efficiency	
Floor Insulation	R-17.4
Wall/Door Insulation	R-12.1
Ceiling Insulation	R-26.0
Window R-Value	R-4.35
Window to Wall Ratio, Living Space	10.1%
South Facing Window Area	42 square feet
Air Leakage	17.8 Air Changes per Hour at 50 Pascals 0.83 Air Changes per Hour Natural
Space Heating System	
System Efficiency	59%
Fuel Type	#2 Oil
Supplemental Fuel	Birch Wood
Thermostat Setting	70.0 degrees F
Setback Thermostat	None
Water Heater	
Efficiency	55%
Location	Conditioned Space
Fuel Type	#2 Oil
Space Cooling System	
Ventilation	None Present
Other	
Number of Occupants	5
Clothes Dryer Fuel	Electricity
Cooking Range Fuel	Electricity
Miscellaneous Lights/Appliance Use	Average

DOES NOT COMPLY WITH BUILDING ENERGY EFFICIENCY STANDARD. Does not receive enough points (89.0 points required). Home does Not meet Air Tightness Requirements.

ver. 2.3.2.1, library: 9/24/2013, file: Happy Homeowner.hm2

Estimated Annual Energy Costs

Use and costs may vary from these estimates based upon weather conditions, occupant life styles and temperatures currently in effect.

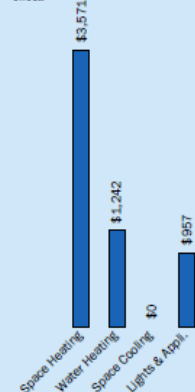

Electricity: \$0.143¢/kWh, #2 Oil: \$3.75/gallons, Birch Wood: \$230/cords
Space Heating: 492 kWh of Electricity, 715 gallons of #2 Oil, 3.46 cords of Birch Wood
Water Heating: 329 gallons of #2 Oil
Space Cooling:
Lights & Appliances: 6,650 kWh of Electricity

Energy Cost & Features

Shows current energy features of home.

Poor insulation

Drafty

Inefficient



Energy Efficiency Improvement Options

Property: energy efficiency
110 full throttle
Anchorage, AK 99517

House: Multi-Family, One Unit
Living Floor Area: 1,500 sq.ft
2-Car Attached Garage

Initial Rating: Two Star, 54.3 points
Additional Rating Points needed to reach higher Rating Levels:

5.7 more points needed to reach 2+ Stars
13.7 more points needed to reach 3 Stars
18.7 more points needed to reach 3+ Stars
23.7 more points needed to reach 4 Stars
28.7 more points needed to reach 4+ Stars
33.7 more points needed to reach 5 Stars
37.7 more points needed to reach 5+ Stars

Rater: AHFC Rater
AHFC
Boniface
Anchorage

ID: read a rating

Fuel Prices used in this Analysis: Electricity = \$0.1242/kWh, Natural Gas = \$0.75/ccf

The following are possible energy-saving improvements for your home.

Notes: The Rating points you receive for each improvement depend upon the other measures you install. In the report below, the points indicated for each measure assume that you install all prior measures on the list. The Break-Even cost is the most you could pay for the improvement and still have it be cost-effective based on energy savings over the life of the measure.

Improvement Description / Location	Annual Savings ¹	Break Even Cost ²	Rating Points Gained ³	Rating, after all Improvements thru this one ⁴	Design Heat Loss, Btu/hr ⁵
Fill empty 2x12 cavity with R-38 blown-in dense-pack insulation . Location - Exposed Floor: garage floor	\$189	\$4,134	4.6	59.9 points 2 Stars Increase: 4.6 pts, 0 steps	52,572
Add R-19 fiberglass batts to masonry wall. Cost does not include studs or furring strips. Location - Below- (part or all) Grade Wall: crawl space	\$117	\$2,564	2.8	62.7 points 2+ Stars Increase: 7.4 pts, 1 step	49,760
Install Lexan magnetic storm window on interior Location - Window/Skylight: 2nd floor skylights	\$29	\$456	0.7	63.4 points 2+ Stars Increase: 0.7 pts, 1 step	49,053
Caulk and Seal so that Home Air Leakage is Reduced by 1500 CFM at 50 Pascals.	\$422	\$3,784	10.2	73.6 points 3 Stars Increase: 10.3 pts, 2 steps	38,391
Add R-5 insulating blanket to garage door Location - Garage Door: garage overhead door	\$35	\$441	0.8	74.4 points 3+ Stars Increase: 0.9 pts, 3 steps	37,536
Add R-21 blown cellulose insulation to attic with Standard Truss. Location - Ceiling w/ Attic: garage attic	\$32	\$698	0.8	75.2 points 3+ Stars Increase: 0.9 pts, 3 steps	36,795
Install R-14 rigid board insulation Location - Exposed Floor: House floor	\$73	\$1,594	1.8	76.0 points 3+ Stars Increase: 0.7 pts, 3 steps	35,092
Add R-21 blown cellulose insulation to attic with Standard Truss.	\$55	\$1,204	1.3	77.3 points 3+ Stars	33,795

Energy Efficiency Improvement Options report

Shows the eligible improvements.

Look at:
"Rating Points Gained"

Listed in order of most cost-effective to least cost-effective improvements.

Energy Efficiency Improvement Options

Property: energy efficiency
110 full throttle
Anchorage, AK 99517

House: Multi-Family, One Unit
Living Floor Area: 1,500 sq.ft
2-Car Attached Garage

Rater: AHFC Rater

Initial Rating: Two Stars, 54.3 points
Additional Rating Levels: Each higher

Rating Levels:

5.7 more points needed

13.7 more points needed

18.7 more points needed

23.7 more points needed

28.7 more points needed

33.7 more points needed

37.7 more points needed

Fuel Prices used in this report:

Gas = \$0.124/cf Oil = \$0.75/ccf

The following are possible improvements:

Notes: The Rating points you receive will be based on the other measures you install. In the report below, the points indicated are based on the assumption that you install all prior measures on the list. The Break-Even cost is the *most* years it will take to pay for the measure and still have it be cost-effective based on energy savings over the life of the measure.

Improvement Description / Location	Cost	Payback (Years)	Rating Points Gained ^a	Rating, after all Improvements thru this one ^a	Design Heat Loss, Btu/hr ^a
Fill empty 2x12 cavity with R-38 blown-in dense-pack insulation. Location - Exposed Floor: garage floor			4.6	58.9 points 2 Stars Increase: 4.6 pts, 0 steps	52,572
Add R-19 fiberglass batts to masonry walls. Cost does not include studs or framing. Location - Below- (part or all) crawl space				61.7 points 2+ Stars Increase: 4.6 pts, 1 step	49,760
Install Lexan magnetic storm doors. Interior. Location - Window/Skylight: skylights	\$29	\$44		61.7 points 2+ Stars Increase: 4.6 pts, 1 step	49,053
Caulk and Seal storm doors. Reduced by 1500 Btu/hr	\$422	\$3,787			38,391
Add R-5 insulation to garage door. Location - Garage Door: garage overhead door	\$35	\$441	0.8	3+ Stars Increase: 19.1 pts, 3 steps	37,536
Add R-21 blown cellulose insulation to attic with Standard Truss. Location - Ceiling w/ Attic: garage attic	\$32	\$698	0.8	74.2 points 3+ Stars Increase: 19.9 pts, 3 steps	36,795
Install R-14 rigid board insulation. Location - Exposed Floor: House floor	\$73	\$1,596	1.8	76.0 points 3+ Stars Increase: 21.7 pts, 3 steps	35,092
Add R-21 blown cellulose insulation to attic with Standard Truss.	\$55	\$1,207	1.3	77.3 points 3+ Stars	33,795

- If you plan to install less efficient products, such as a lower-efficiency heating system or water heater, than recommended in the Energy Efficiency Improvement Options report, you may receive fewer points.
- You must contact your rater to re-run your Energy Efficiency Improvement Options report to determine the estimated points you will receive with the lower efficiency products you plan to install.

Products which MIGHT be recommended in a SPECIFIC energy rating

- Garage blankets & insulated garage doors
 - Windows and doors
 - Water heater blankets
 - Air sealing products: caulk, spray foam, weatherstrip
 - Insulation
 - Heating systems
 - Water heating systems
 - Programmable thermostats
 - Ventilation systems (exhaust fan, HRV)
-

IMPORTANT!

- AHFC does not “accept”, “endorse”, “recommend” or “approve” products or contractors.
 - Installation techniques and products must follow manufacturer’s instruction and all applicable building codes and standards.
 - Understand the “house as a system”
-

Rating or Rater Issues?

Questions about your rating?

Rater complaints?

1. Call your energy rater first.
2. If there is still a problem contact:

AHFC

1-907-330-8166 or 1-800-478-4636

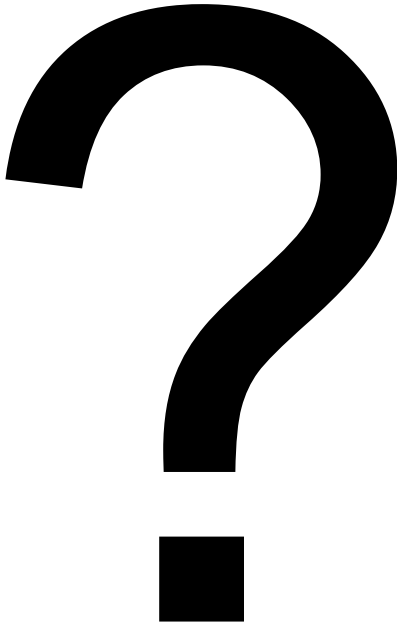

Understanding Energy Improvements

Building Science 101

The House is a System

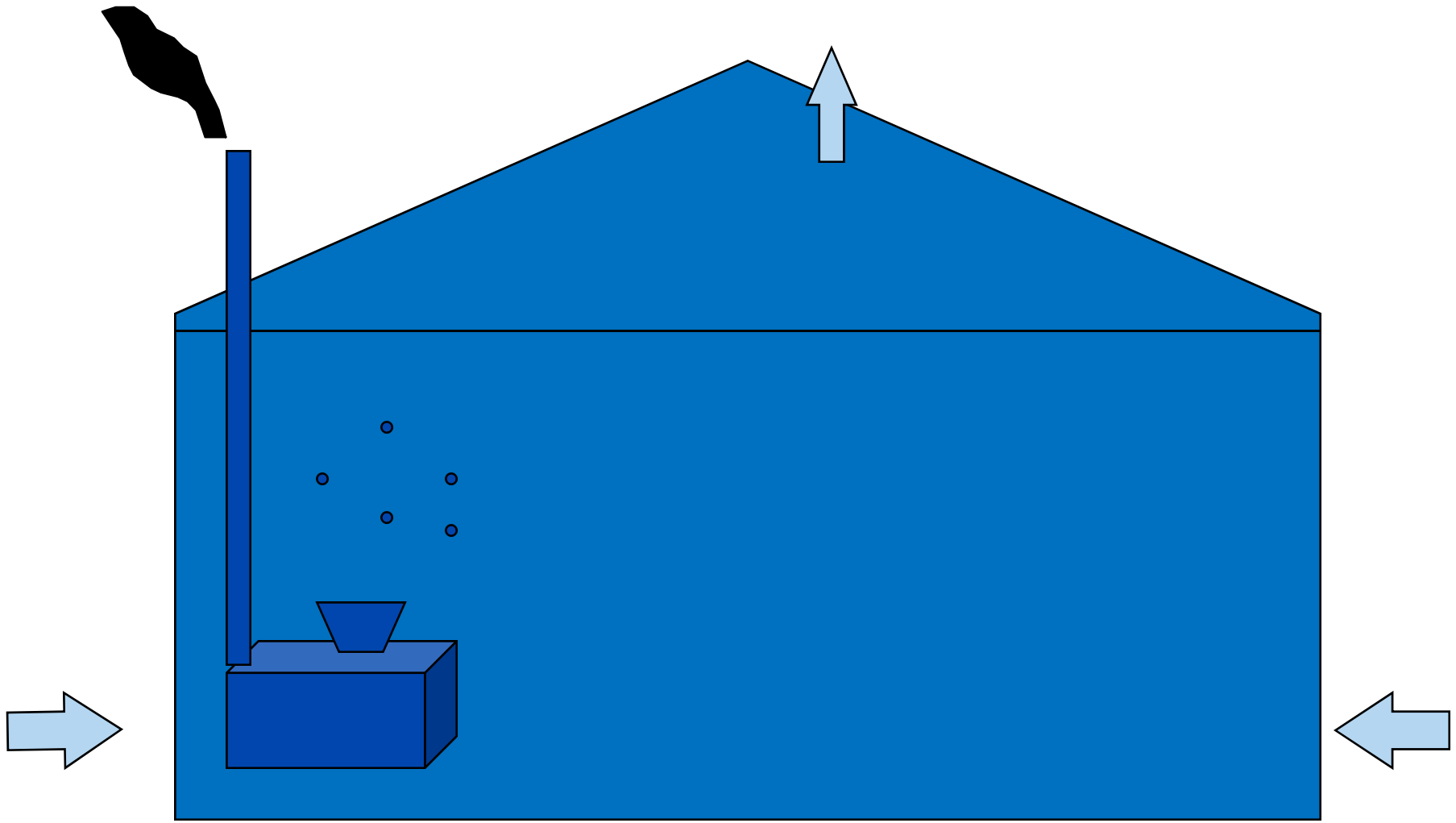

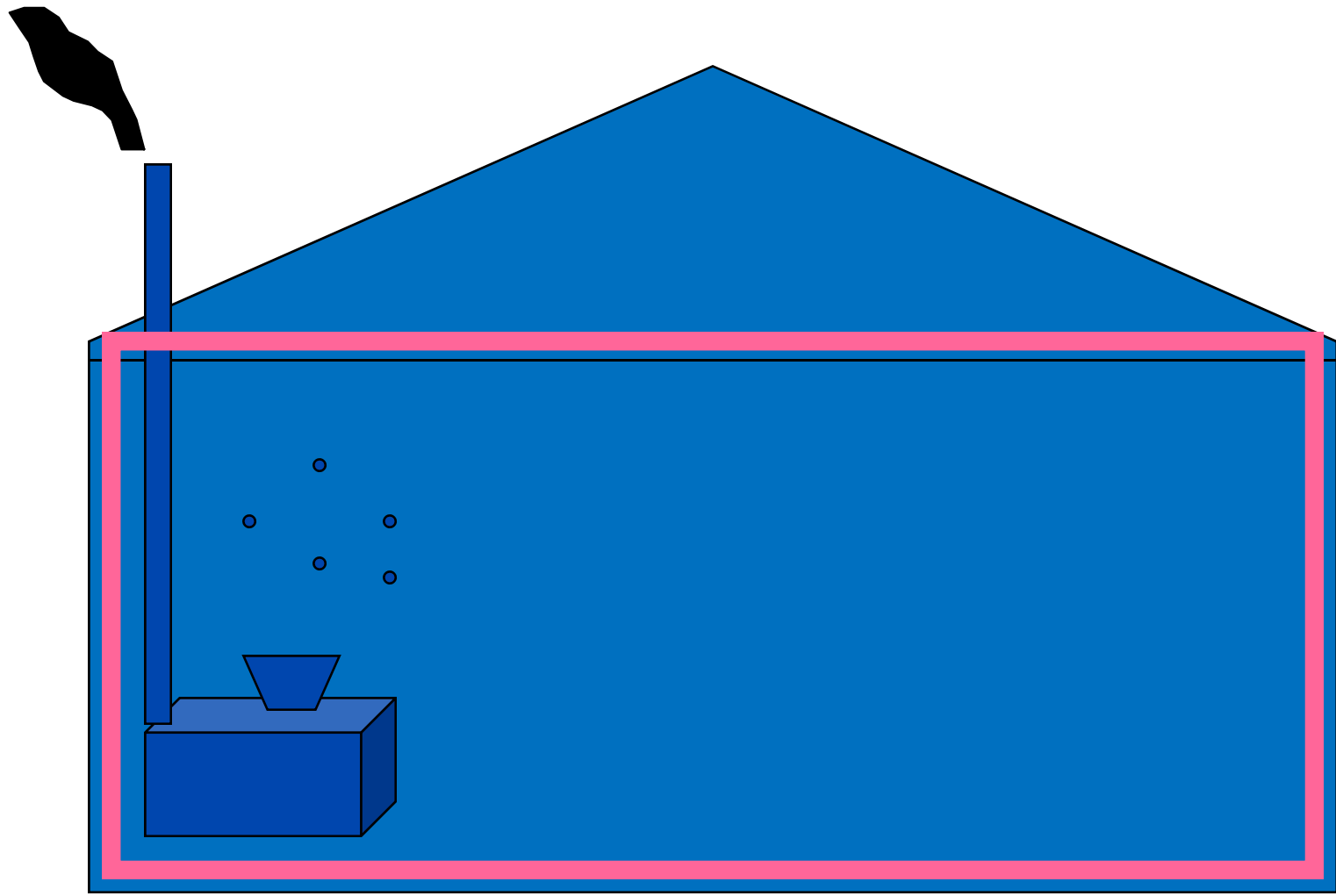

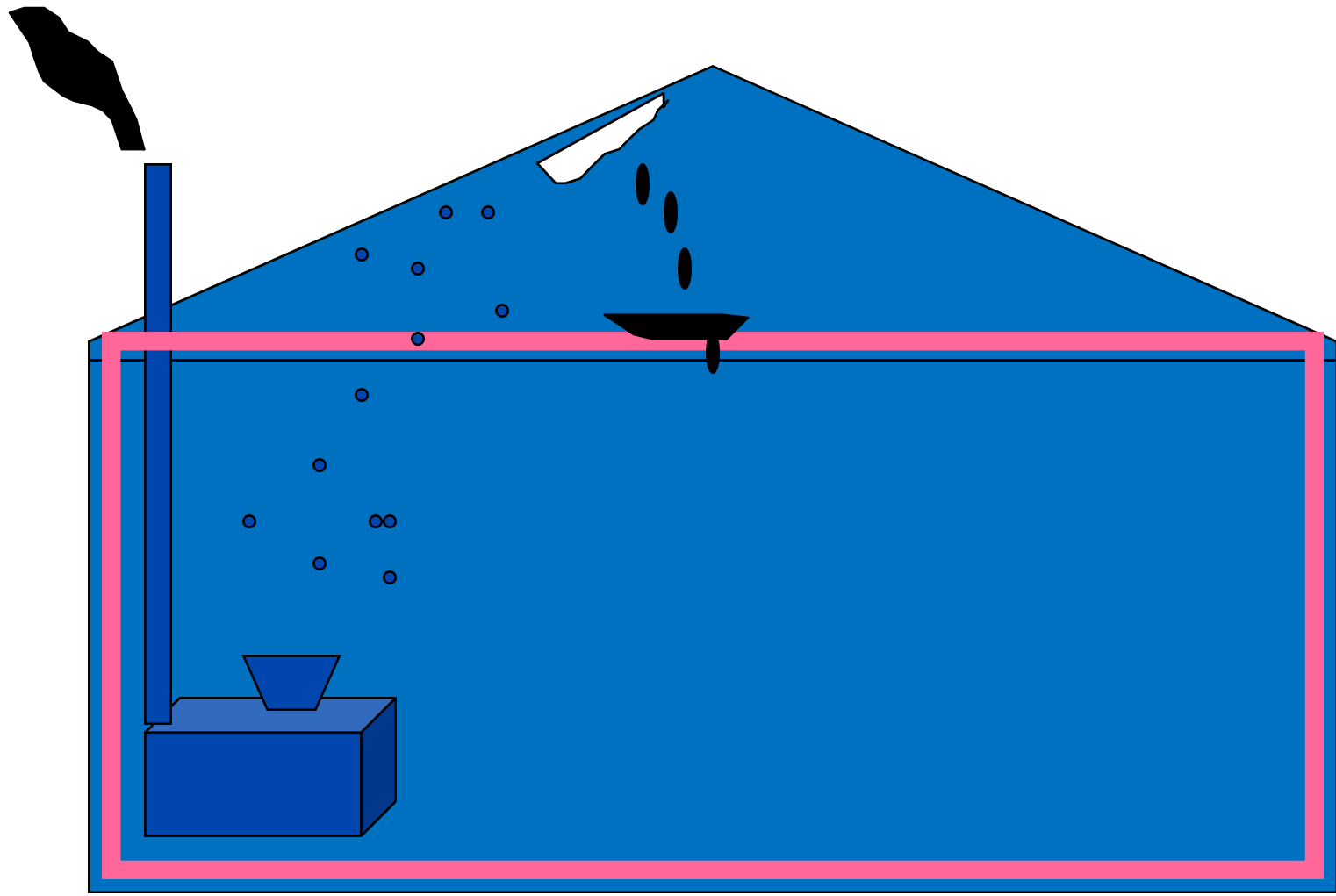







As we move to the inside...

Vaulted ceiling with recessed lighting. No the roof wasn't leaking.



Major heat loss from skylights – notice the melted snow causing ice dams.



Photos Courtesy of AHFC



Retrofit LED Recessed Lighting

These airtight, insulation-contact recessed cans with LED lights use 10.5 watts. The 10 lights in this room use about the same electricity as ONE 100-watt bulb. Reduces air leakage into attic.

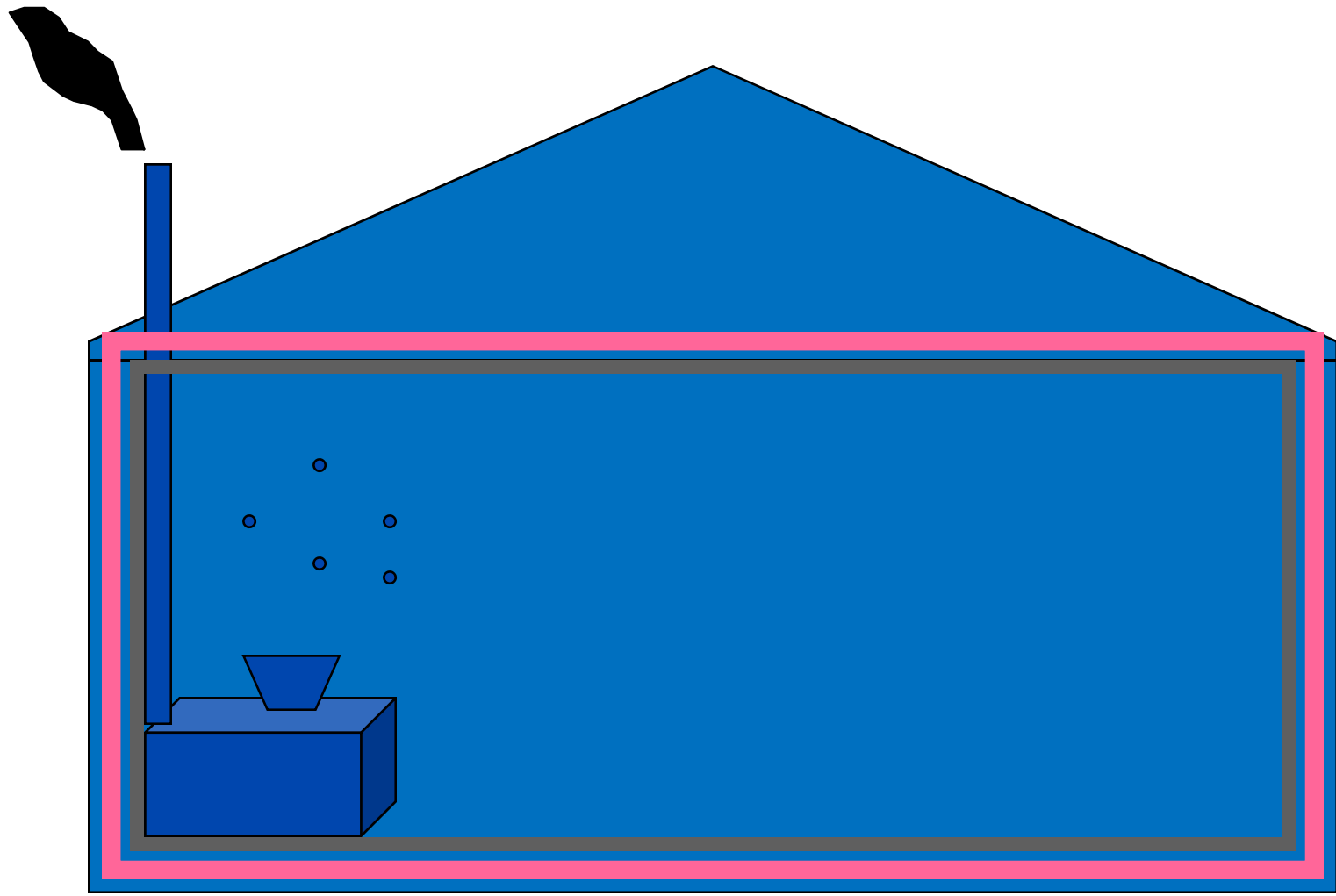

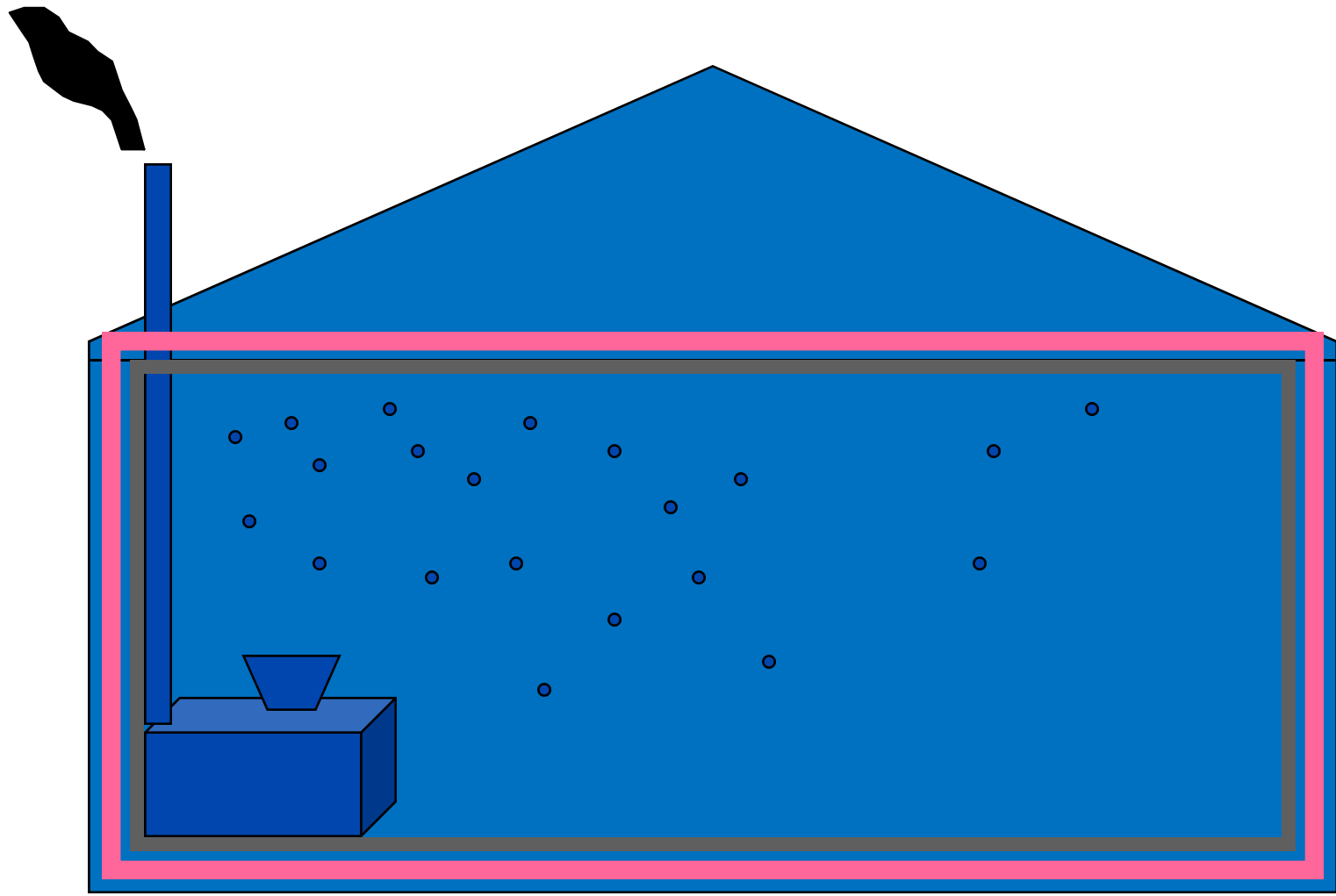





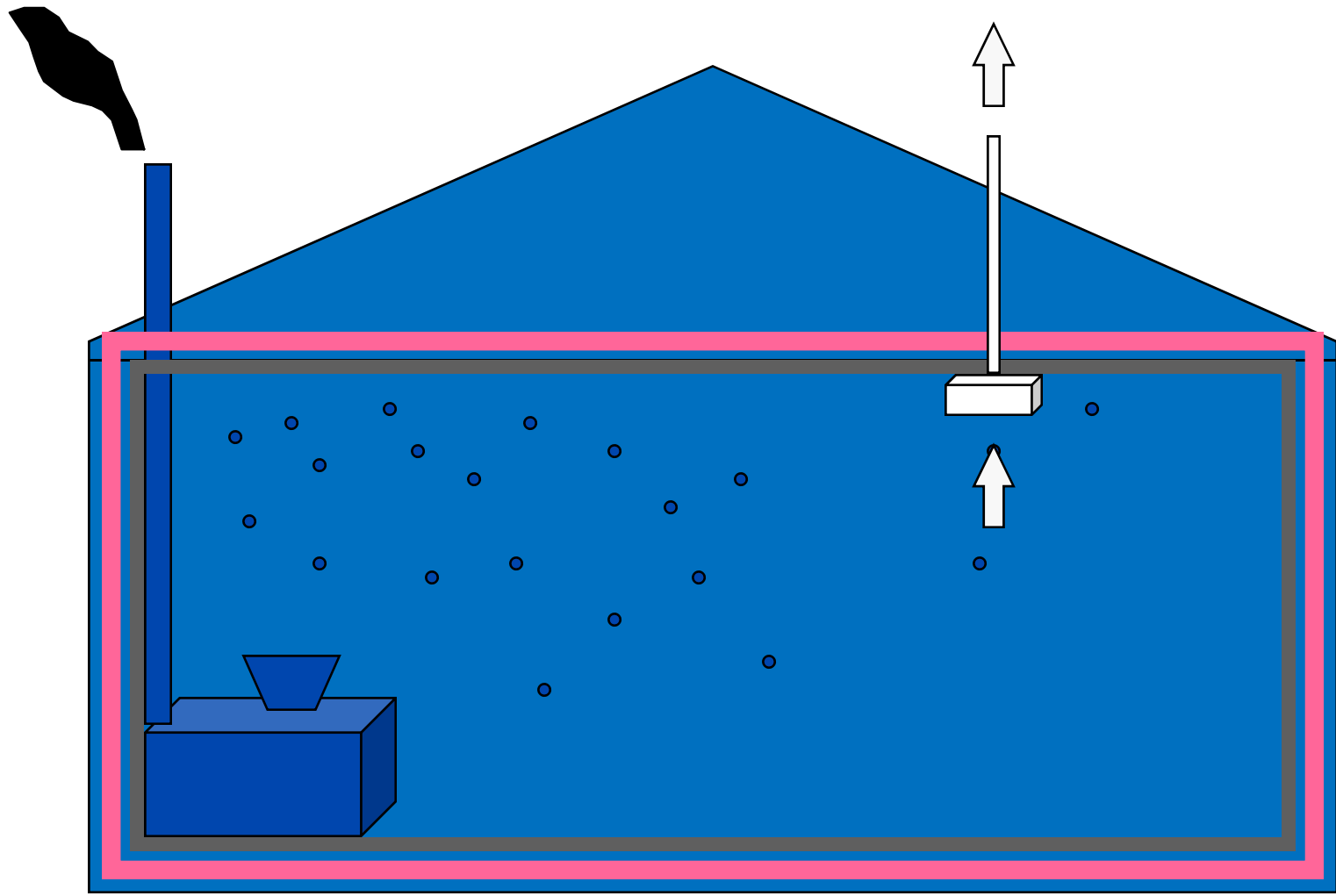

Ventilation System

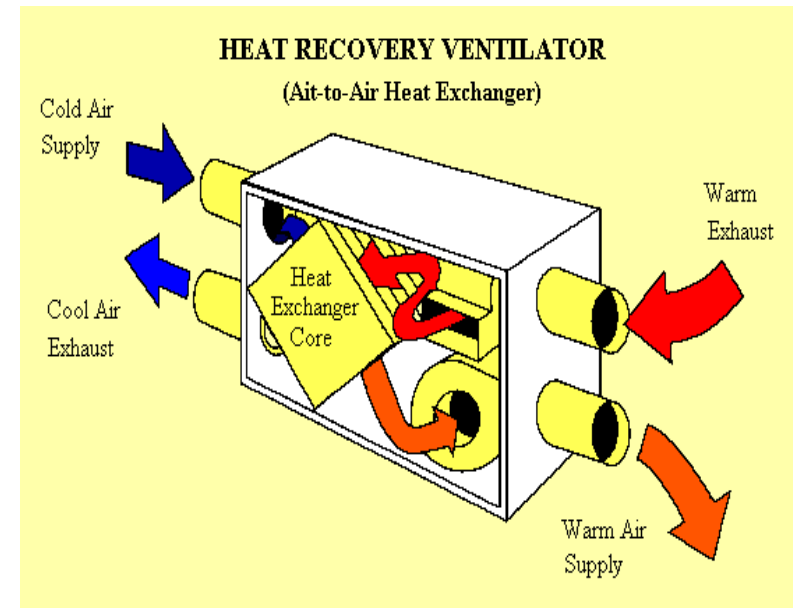
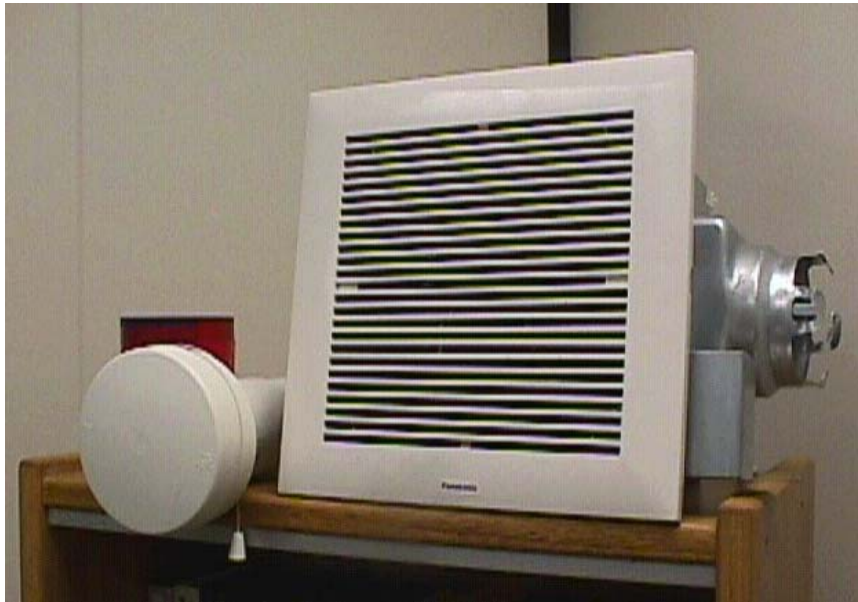

“Build tight, ventilate right”

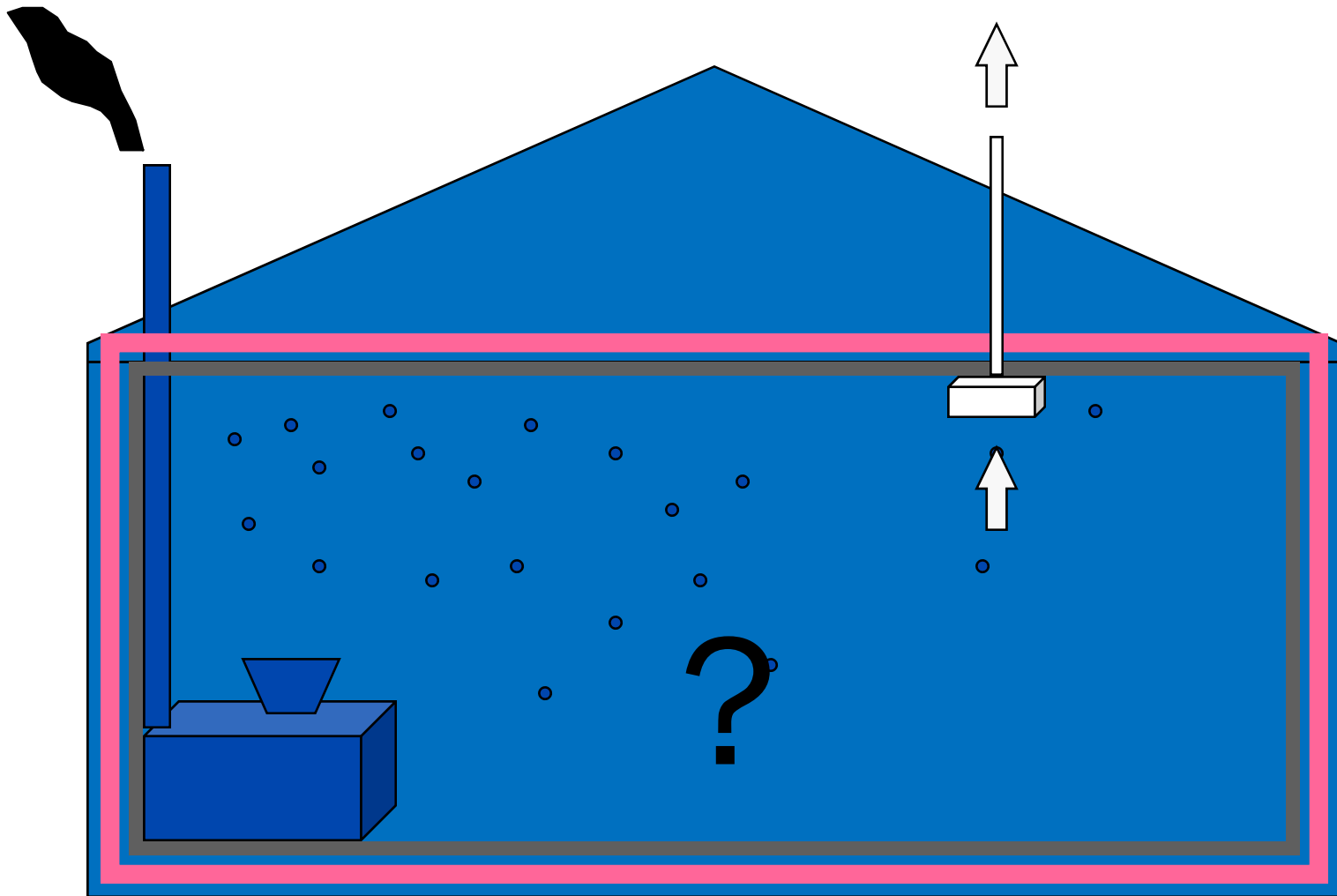

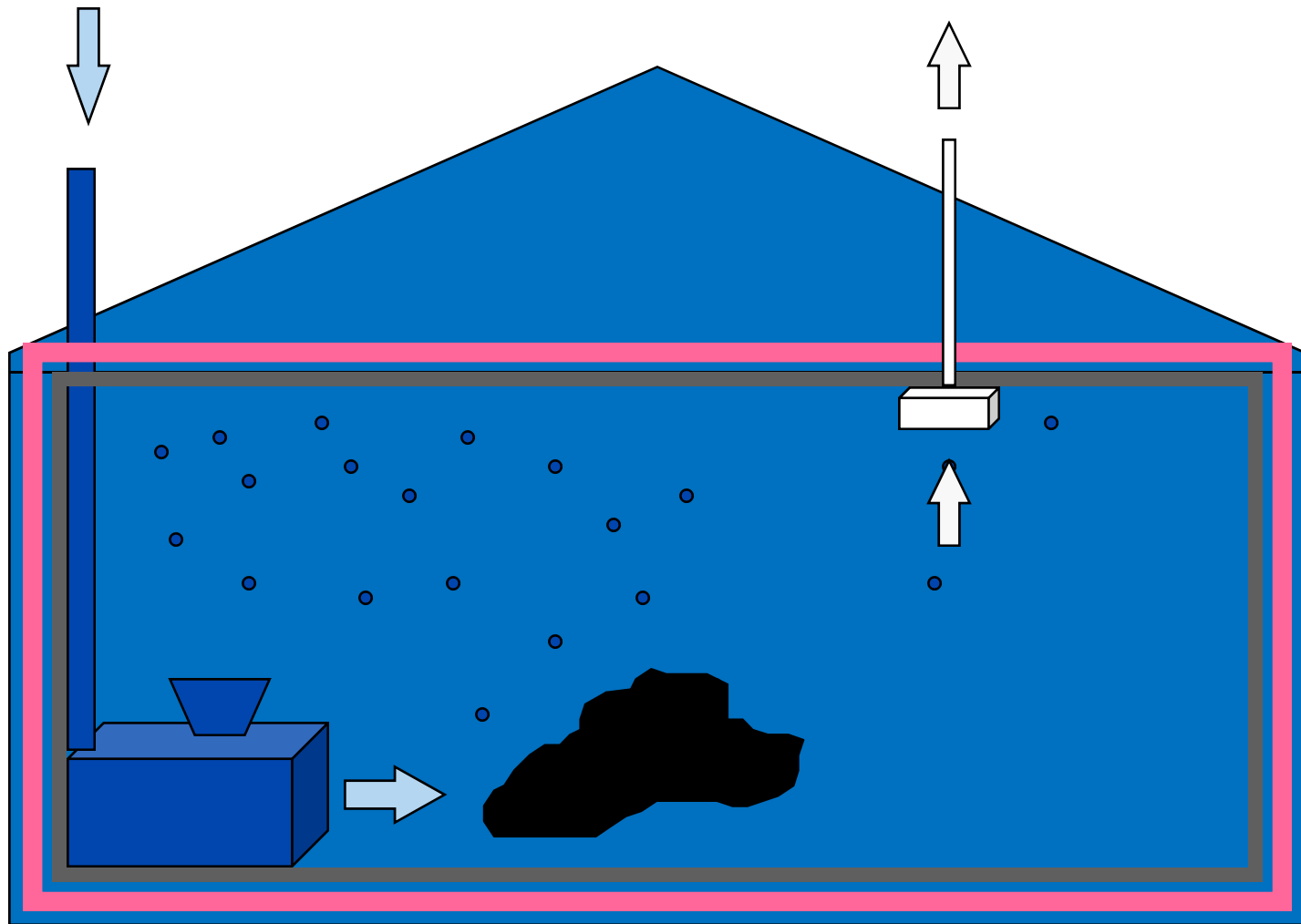

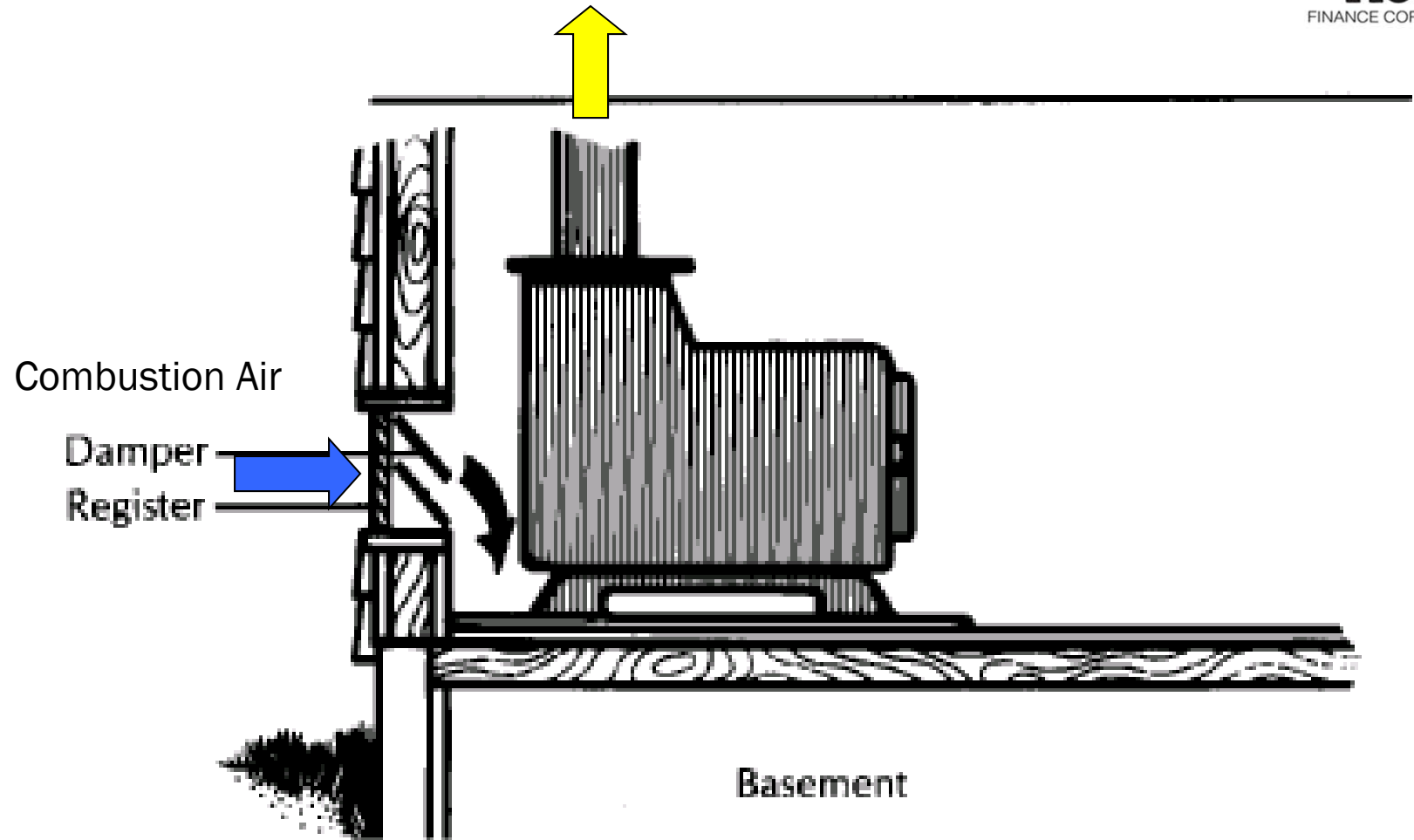

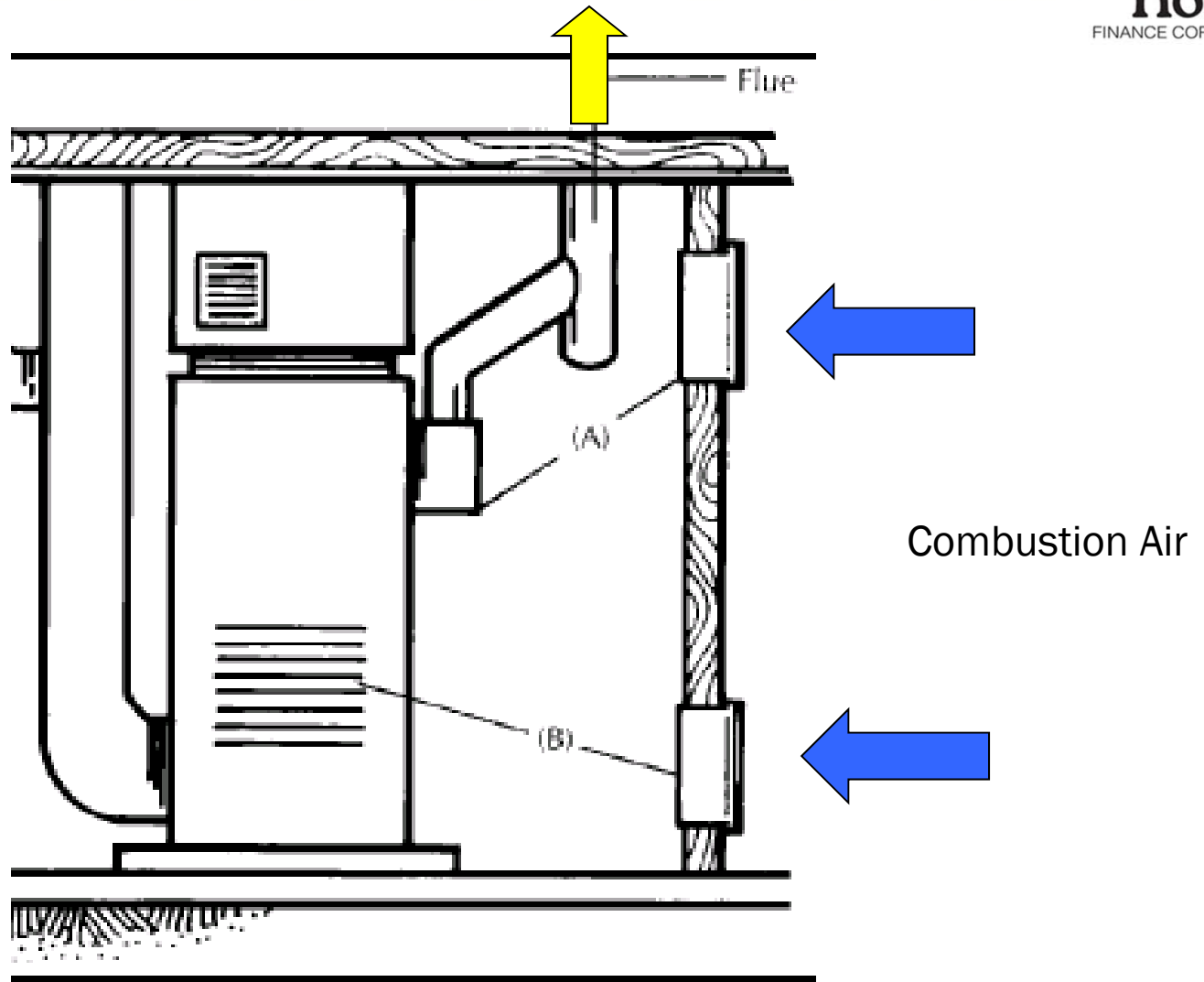

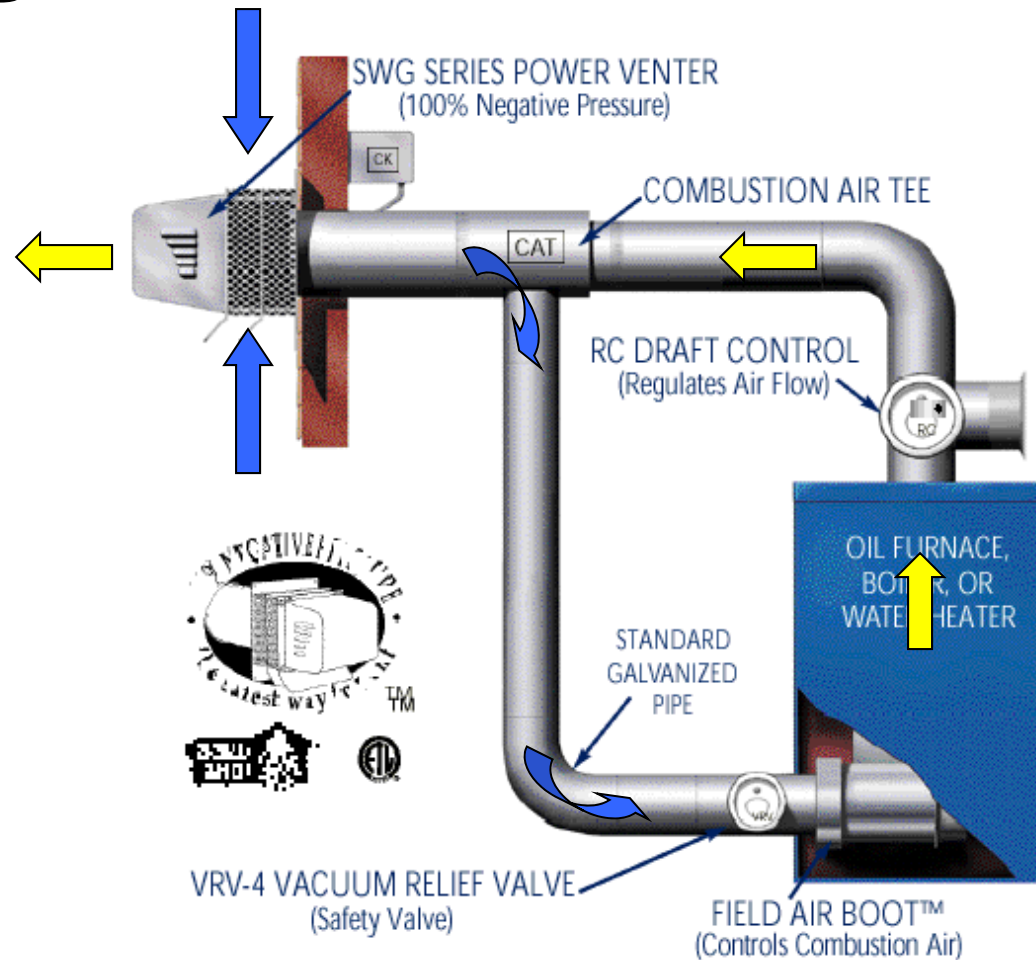

Direct Vent or Sealed Combustion Heating & Hot Water Heaters



Air Sealing & Insulating Information



A photograph of a smiling family of three—a man, a woman, and a young child—sitting on the steps of a house. The man is on the left, the woman is in the middle, and the child is on the woman's lap. They are all dressed in casual attire.

A DO-IT-YOURSELF GUIDE TO SEALING
AND INSULATING WITH ENERGY STAR®
SEALING AIR LEAKS AND ADDING ATTIC INSULATION



ENERGY STAR



More information at www.energystar.gov

Some items may qualify for federal tax credits.

Plug the holes in the ceiling

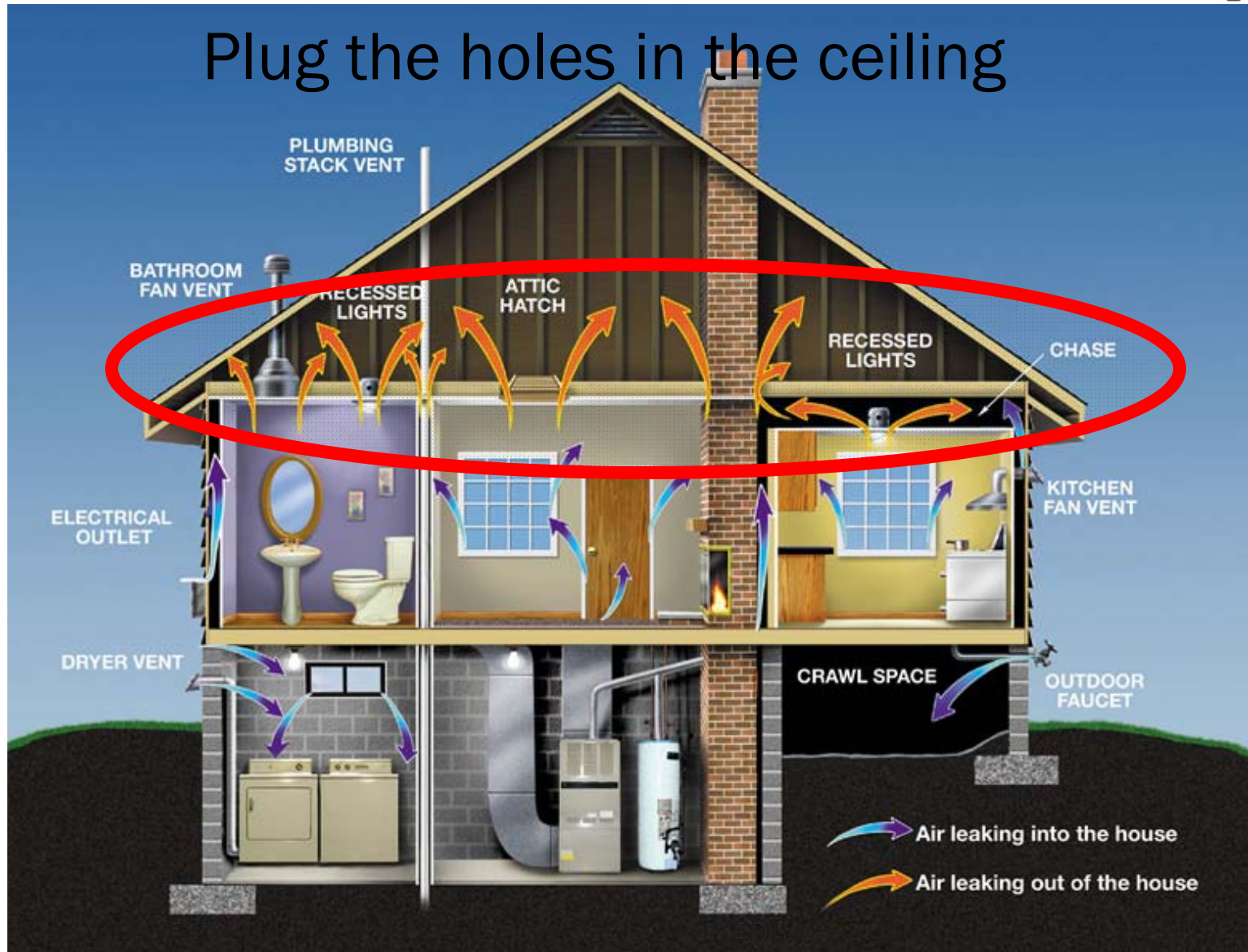

11. WEATHERSTRIP THE DOOR

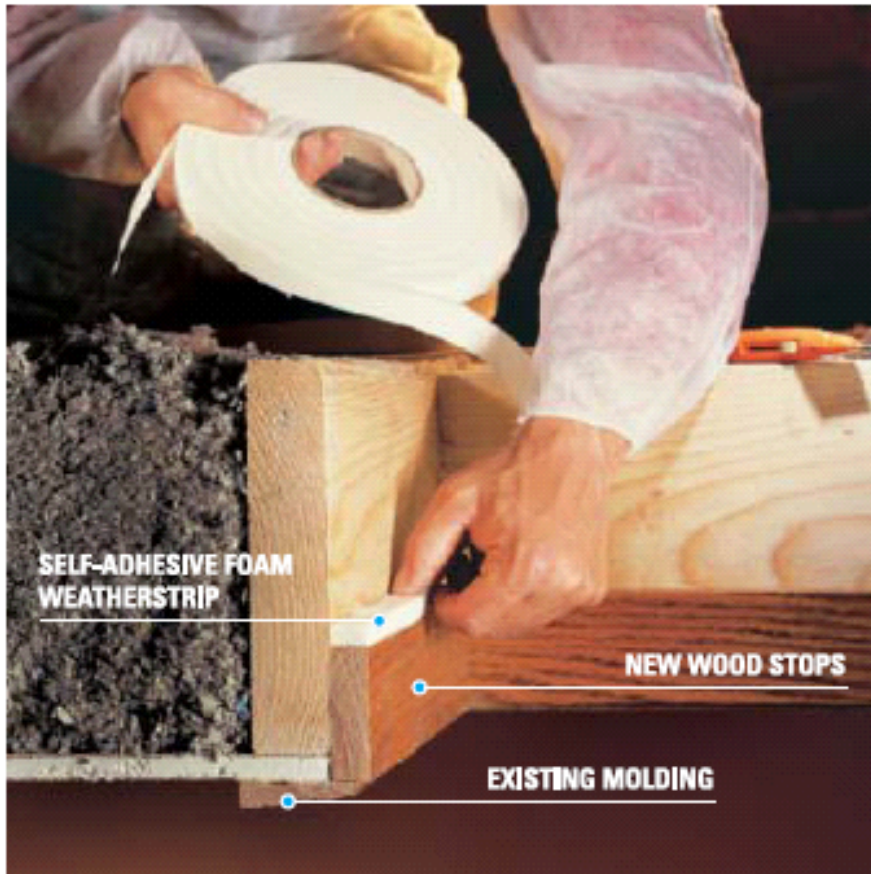

12. ATTACH FASTENERS

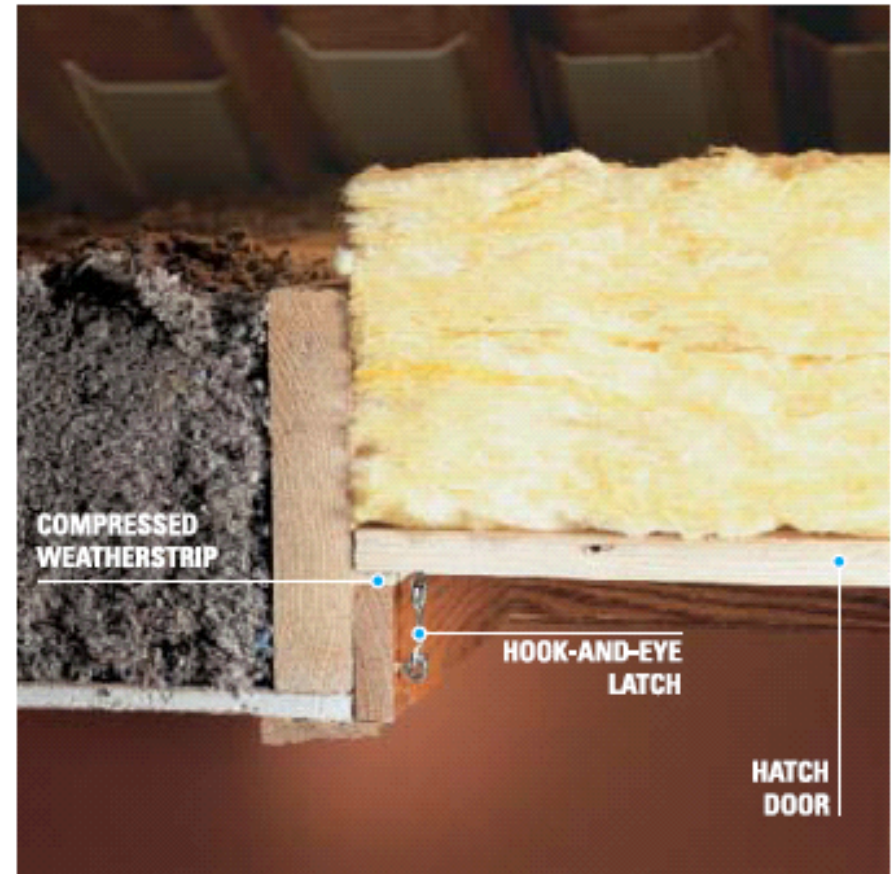



Baffles

Baffles had to be extended to allow for additional insulation. Baffles prevent insulation from blocking the attic ventilation brought in through the soffit vents.

9. FILL HOLES WITH CAULK



10. STUFF GAPS WITH INSULATION

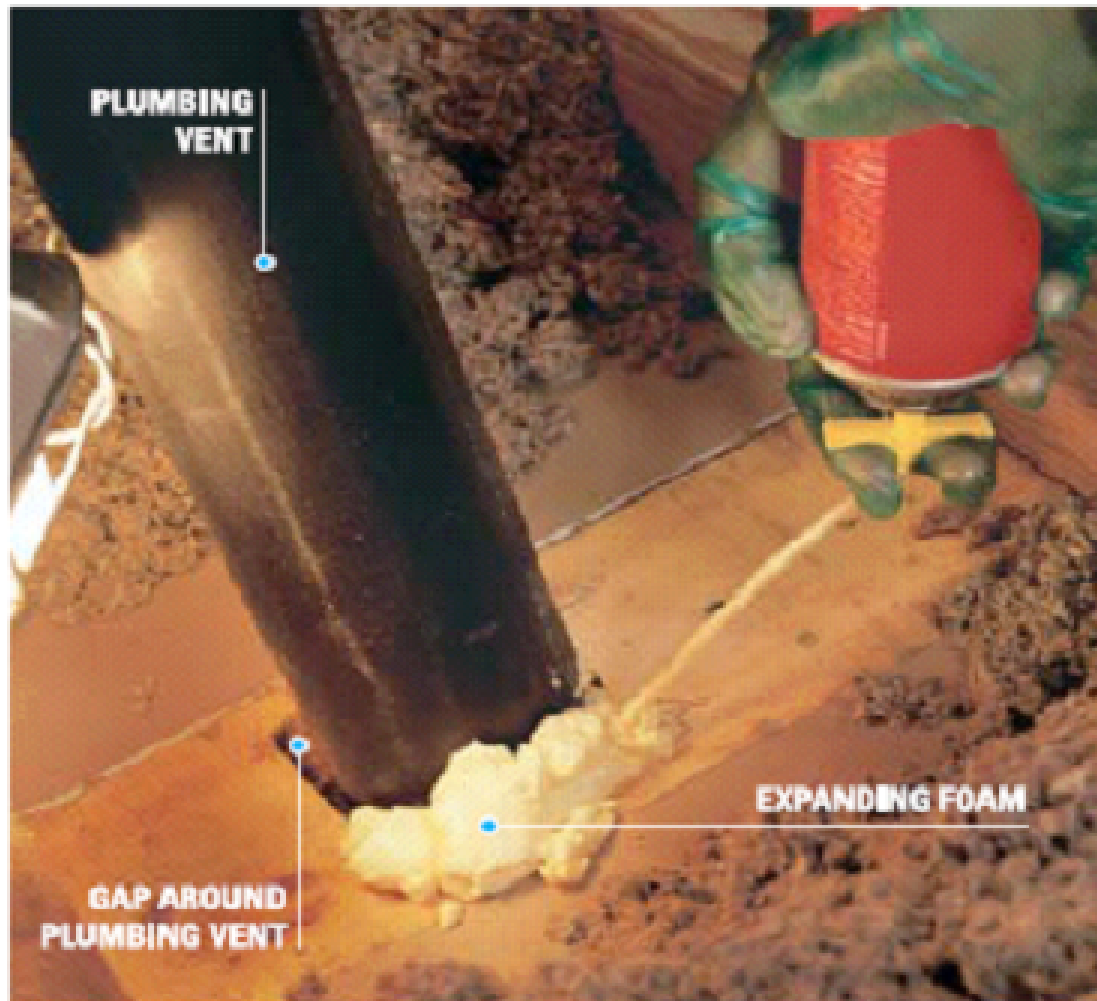

5. CUT ALUMINUM FLASHING



And SEAL LOW!

Areas to Caulk or Foam

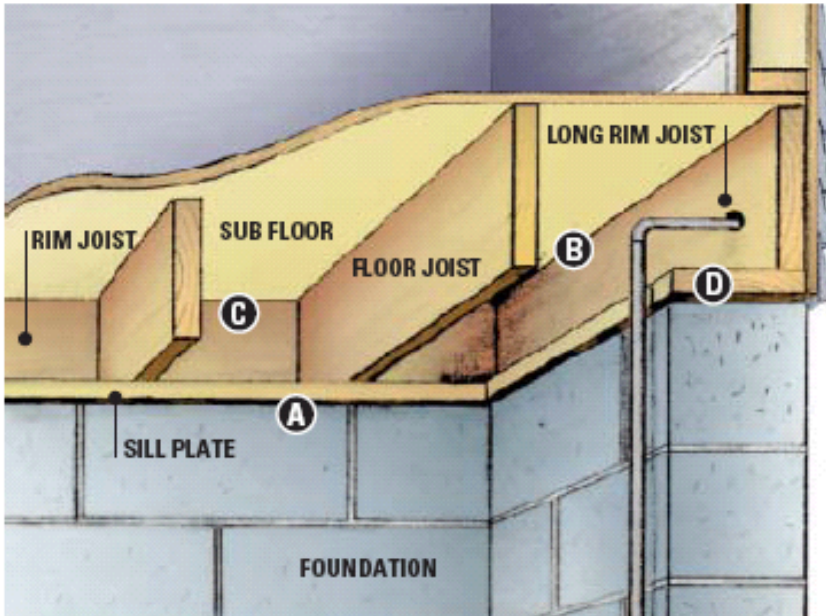

ILLUSTRATION BY DALE HOFFMEYER

Seal and Insulate





Sill plate where the house sits on the foundation

This is a basement. Note the dark insulation where the wires are visible..



The sill plate was sprayed with foam

This air-sealed the sill plate and replaced the fiberglass insulation.

Air Sealing Tips

- Seal BEFORE insulate.
- Seal high and low
- Use special care around items which produce heat (like chimneys, recessed light fixtures).
- Add mechanical ventilation for good indoor air quality

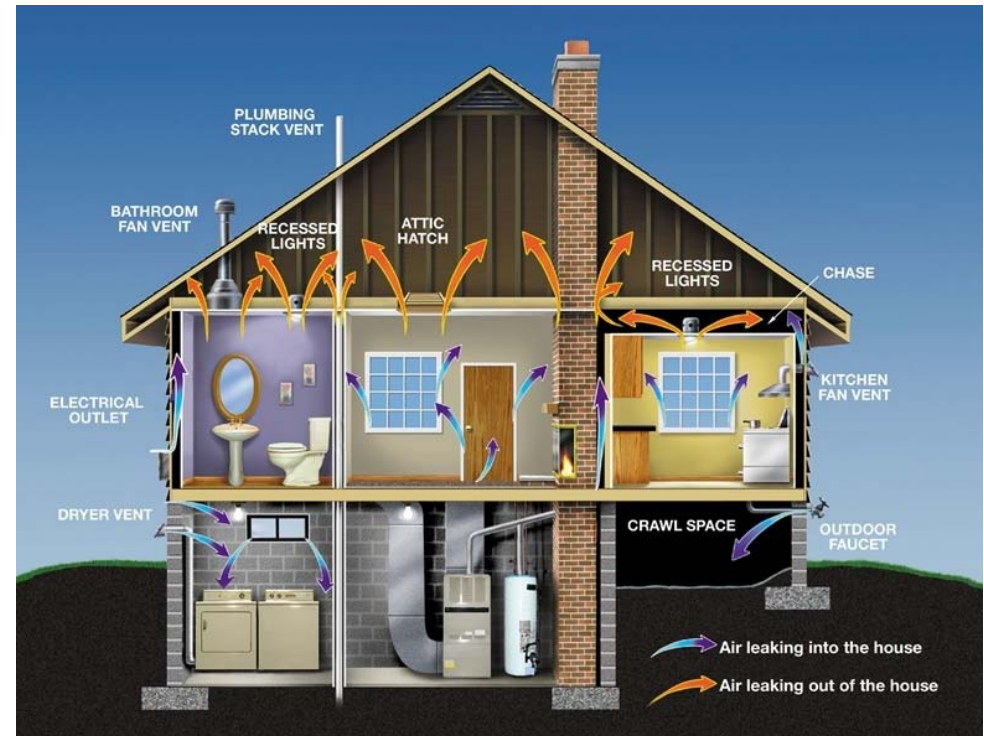

More information at www.energystar.gov



Insulating Tips

- Install properly*
- Count bags for blown-in type insulation (like cellulose),*
- Do not block roof ventilation*

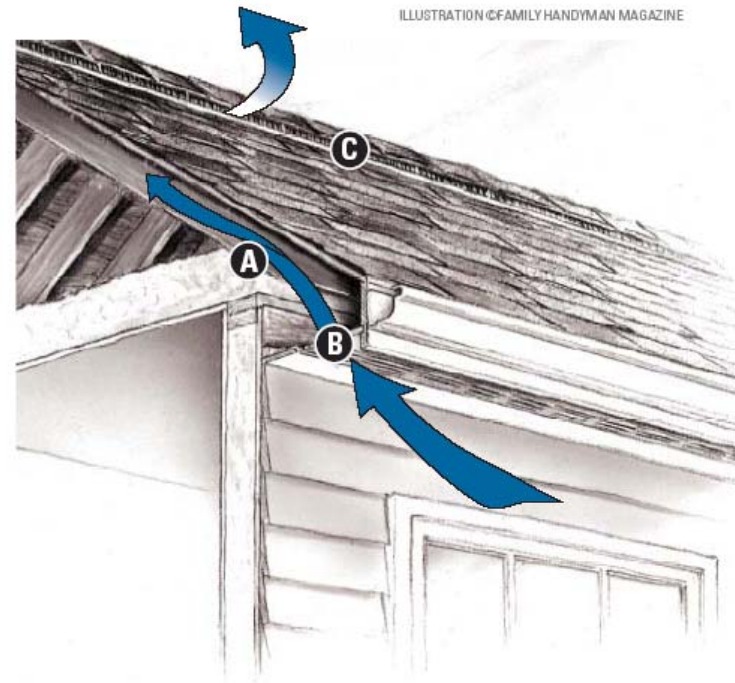

More information at www.energystar.gov

Window & Door Information



NFRC

www.nfrc.org

 <p>NFRC National Fenestration Rating Council® CERTIFIED</p>	<p>World's Best Window Co. Millennium 2000+ Vinyl-Clad Wood Frame Double Glazing • Argon Fill • Low E Product Type: Vertical Slider</p>	
ENERGY PERFORMANCE RATINGS		
<p>U-Factor (U.S./I-P) 0.30</p>	<p>Solar Heat Gain Coefficient 0.30</p>	
ADDITIONAL PERFORMANCE RATINGS		
<p>Visible Transmittance 0.51</p>	<p>Air Leakage (U.S./I-P) 0.2</p>	
<p>Condensation Resistance 51</p>	<p>—</p>	
<p><small>Manufacturer stipulates that these ratings conform to applicable NFRC procedures for determining whole product performance. NFRC ratings are determined for a fixed set of environmental conditions and a specific product size. NFRC does not recommend any product and does not warrant the suitability of any product for any specific use. Consult manufacturer's literature for other product performance information. www.nfrc.org</small></p>		

$$U = 1/R$$

$$R = 1/U$$

Look for the label!

Window Replacement Tips

Keep NFRC window labels to show the rater.

		World's Best Window Co. Millennium 2000+ Vinyl Clad Wood Frame Double Glazing • Argon Fill • Low E Product Type: Vertical Slider	
ENERGY PERFORMANCE RATINGS			
U-Factor (U.S./I-P)	Solar Heat Gain Coefficient		
0.35	0.32		
ADDITIONAL PERFORMANCE RATINGS			
Visible Transmittance	Air Leakage (U.S./I-P)		
0.51	0.2		
Condensation Resistance	—		
51			
<small>Manufacturer declares that their design conforms to applicable NFRC procedures for determining whole product performance. NFRC ratings are determined for a fixed unit of environmental conditions and a specific product size. Consult manufacturer's literature for other product performance information. www.nfrc.org</small>			

Window Technologies

Energy-efficient window technologies are available to produce windows with the U-factor, SHGC, and VT properties needed for any application.

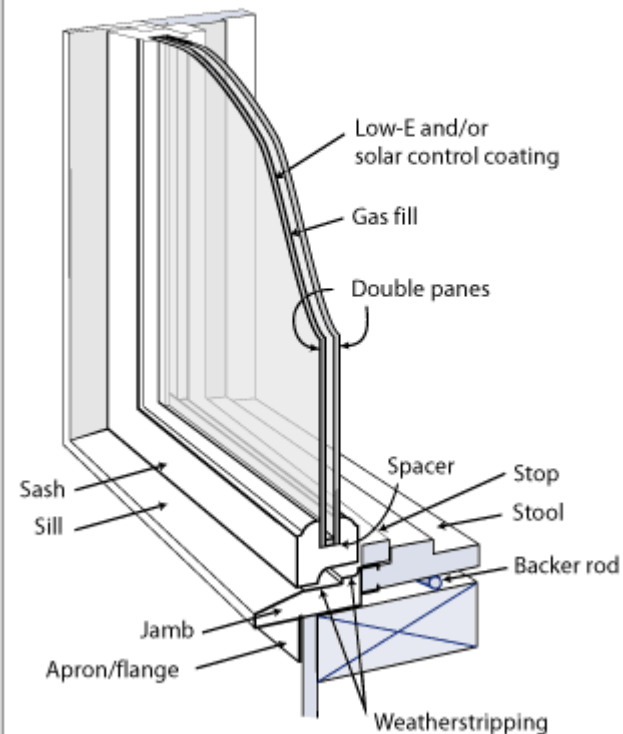

Water Heater & Heating System Information

- Sealed combustion and direct vent systems are safer.
- ACCA Manual J or AkWarm software will properly size a replacement heating system
- Get at least 3 bids for work. Costs may vary considerably

RESEARCH NOTE: Tankless water heaters work in Alaska when properly sized.



Heating & Hot Water Efficiency Info
www.ahrinet.org

Ventilation Tips

- ❑ *Quiet = 1 sone or less*
- ❑ *Continuous duty rated*
- ❑ *Proper sizing*
- ❑ **ENERGY STAR**

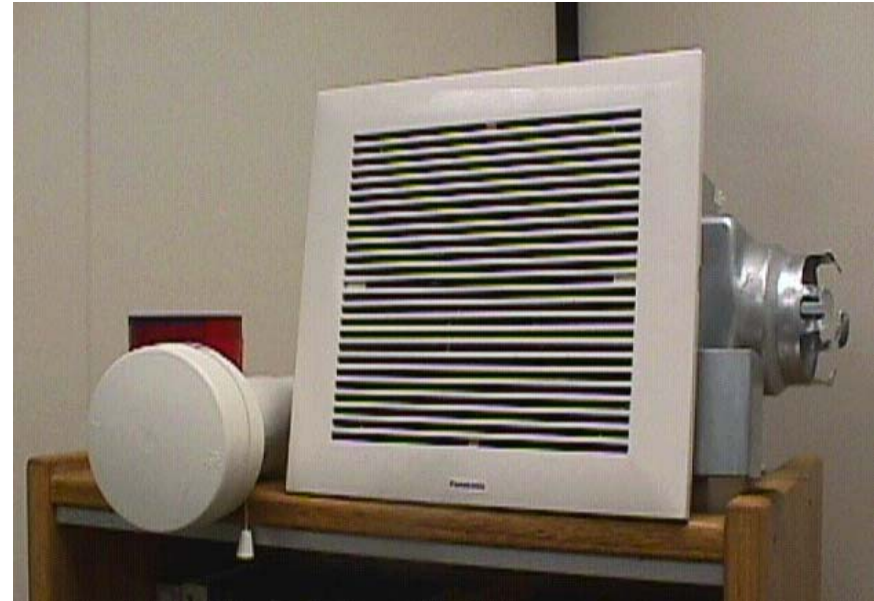

More information at www.energystar.gov &
www.ahfc.us

Whole Building Ventilation Sizing in CFM (cubic feet per minute)

Number of Bedrooms	0-1	2-3	4-5	6-7	>7
<1500 ft²	35	55	75	95	115
1501-3000	50	70	90	110	125
3001-4500	65	85	105	125	145
4501-6000	80	100	120	140	160
6001-7500	95	115	135	155	175
>7500 ft²	110	130	150	170	190

Lighting, Appliances & Tips to Save Money

Alaska Household Energy Costs %

Southeast

Space Heating.....	69%
Water Heating.....	14%
Appliances.....	17%

South Central

Space Heating.....	73%
Water Heating.....	14%
Appliances.....	13%

Interior

Space Heating.....	77%
Water Heating.....	11%
Appliances.....	12%

Western

Space Heating.....	73%
Water Heating.....	10%
Appliances.....	17%

*Statistics are from AHFC's 2014 Housing Needs Assessment.

Measuring Use

- Meters
 - Individual appliances
 - Energy, Power
- Utility Bills
 - Household
 - Energy



P. Cotter

Are your appliances really OFF?

- Phantom loads
 - Some electronic appliances use energy when they are turned off
 - Can be significant, especially if long-term and consistent

This appliance was “OFF”

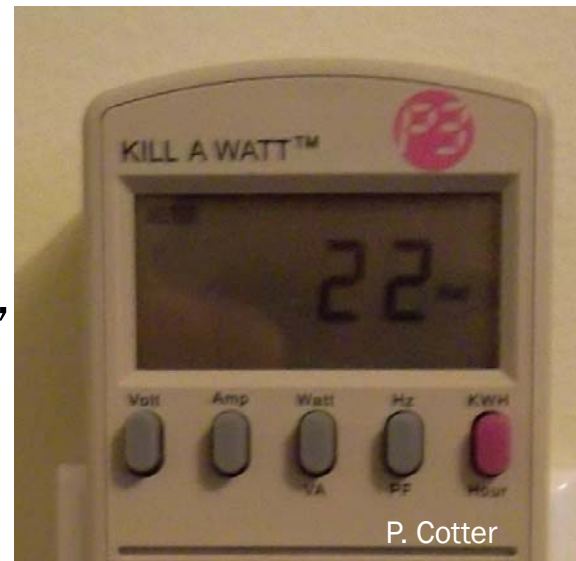

Advanced Power Strips - Example

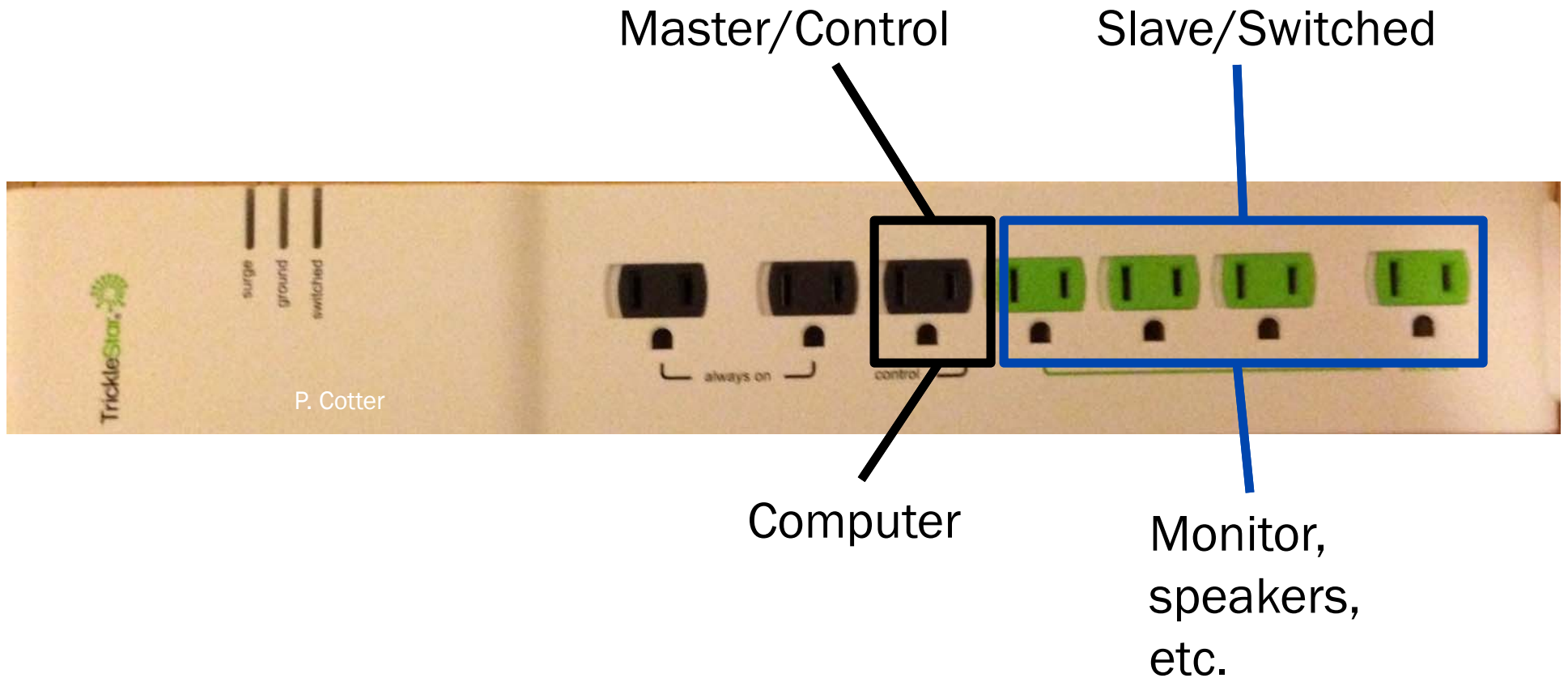

Energy Use Watts:

- Ceiling Fan = 65-175
 - Flat Screen TV 53"- 61" = 120
 - Water Pump = 250-1100
 - CPU + Monitor - Awake = 270
Asleep = 60 or less Laptop = 50
 - Clothes Washer = 350-500
 - Refrigerator 16 cf = 725
 - Furnace Fan = 750
 - Microwave Oven = 750-1100
 - Heater (*portable*) = 750-1500
 - Toaster = 800-1400
 - Coffee Maker = 900-1200
 - Clothes Iron = 1000-1800
 - Hair Dryer = 1200-1875
 - Dishwasher = 1200-2400
 - (*using the drying feature greatly increases energy consumption*)
 - Clothes Dryer = 1800-5000
 - Water Heater (40 gallon) = 4500-5500
-

Calculating the Cost

- Here's the formula to figure the cost of running a device:
- $(\text{Watts} \times \text{hours/day} \times \text{days/year}) \div 1000 \times \text{price per kWh} = \text{cost of electricity per year to operate.}$

Example: Laptop = $(50\text{w} \times 9 \text{ hrs/day} \times 250 \text{ days/year} = 112500 \div 1000=112.5$
 $\times .22 \text{ kwh (Anchorage)} = \24.75 year

Lighting



DOE

By switching a 100-watt bulb to a 23 watt CFL , you could save 75% a year per bulb!



An old school strategy that works



Output and Illumination

- Output - Lumen
 - Ex. 100W incandescent ~ 1600 lumens
- Illumination
 - Foot-candle (FC)
 - 1 lumen spread over 1 sq foot surface

Output and Illumination – How much?

- Safety
 - 5 – 20 FC
- Office work
 - 30 – 50 FC
- Difficult tasks
 - 200 – 500 FC



Light Color/Color Temperature

- Measured in degrees Kelvins (K)
 - Lower K = yellow (like incandescent light)
 - Higher K = white/blue



Light Color/Color Temperature

Energy Star



Watts – Lumens - Color Temperature



Bulb Data

This format is more common for retail sales to consumers

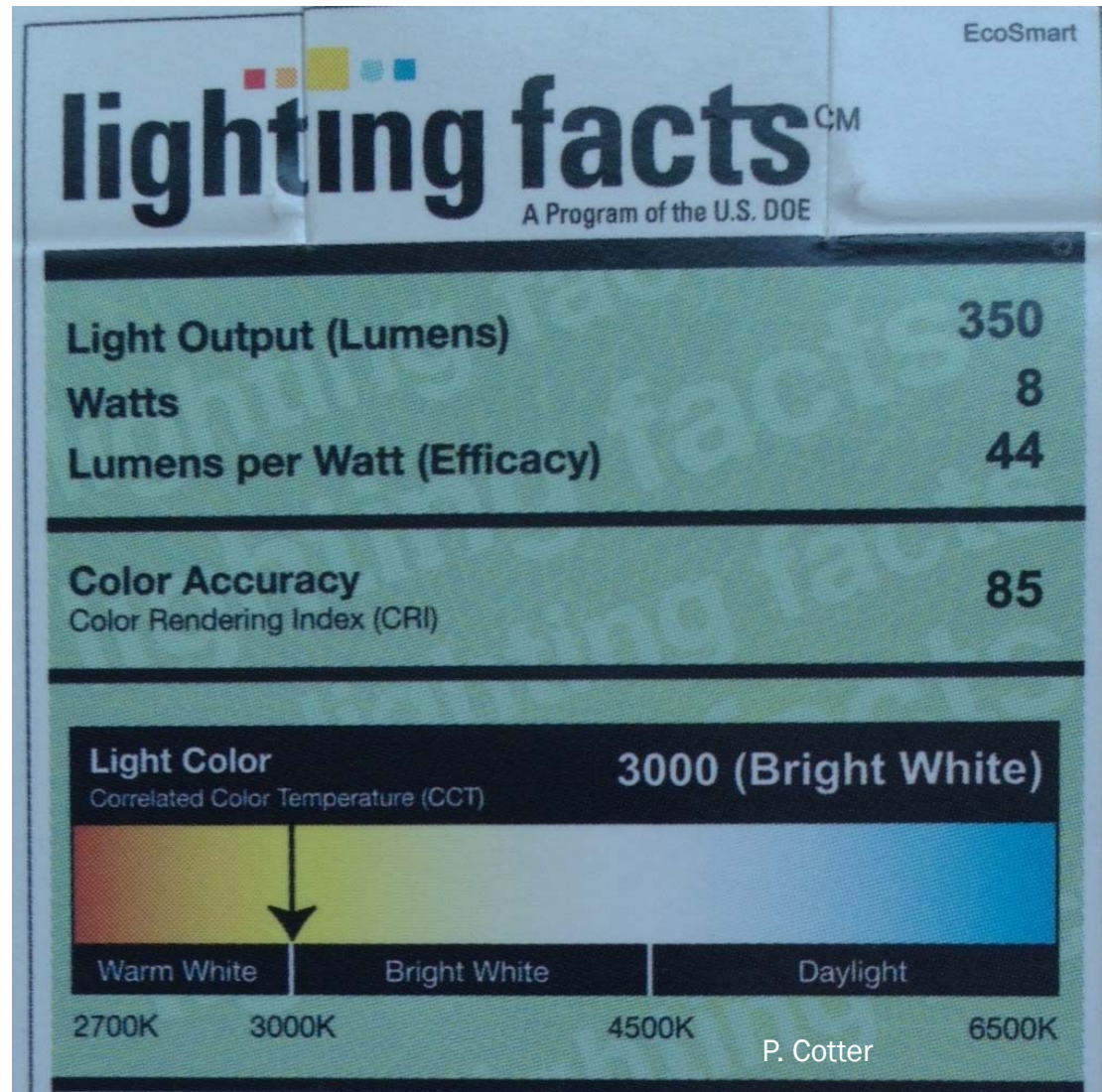

Lighting Uses

- Ambient Lighting
 - Safety and security
- Task Lighting
 - For the work area, not beyond
- Accent Lighting
 - Visual comfort
 - Illuminate walls – less contrast with ceilings/windows

“Light what you want to see.”

Lighting – Bulb Types



P. Cotter

Incandescent - Filament

- Advantages
 - Cheap to purchase
 - Known light quality
 - Known light color
- Disadvantages
 - Inefficient
 - More expensive to use
 - Short lifespan

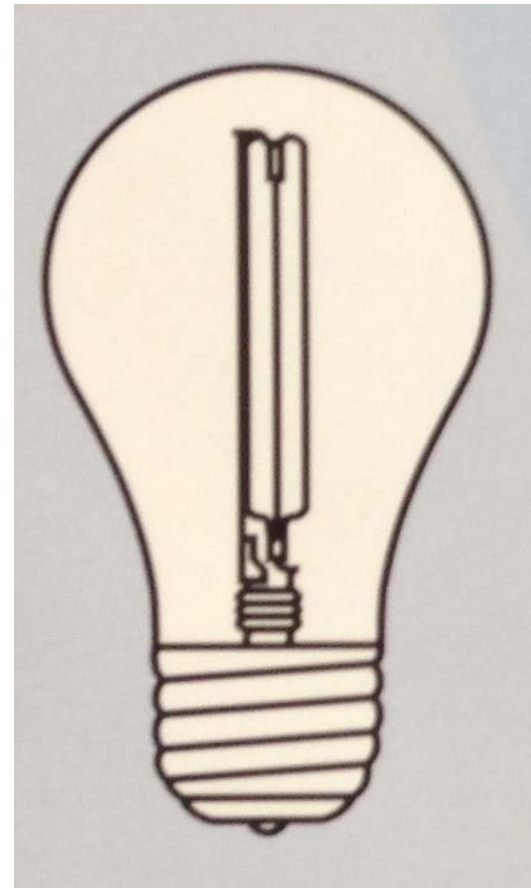

Fluorescent – CFLs

- Advantages
 - Long life
 - Efficient
 - Availability
- Disadvantages
 - Light quality
 - Disposal
 - Poor cold start



Light Emitting Diode - LED

- Advantages
 - Long life
 - Efficient
 - Color options
 - Low temperature performance





Light Emitting Diode - LED

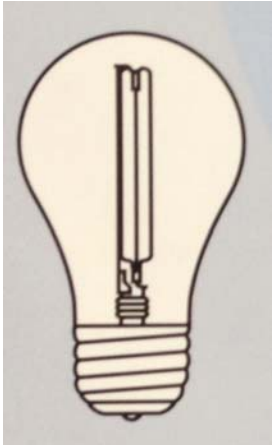

- Disadvantages
 - Higher initial price – coming down rapidly
 - Requires education
 - Availability – more choices
 - Light quality variability

Important lighting equation 1 - lifespan

$$1 \text{ CFL} = 10 \text{ Incandescent}$$

Important lighting equation 2

1



=

25

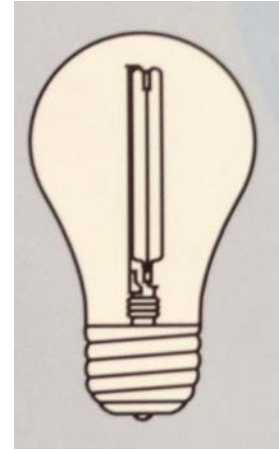

Controls

- On/Off
 - Timers
 - Dimmers – Be sure they are compatible with the bulbs you are using
 - Occupancy/Vacancy Sensors
 - Motion Sensors
 - Photo Sensors
 - Smart controls on mobile devices –
examples Google Home, Amazon Echo, Phillips Hue
-

Not all controls work with all bulbs

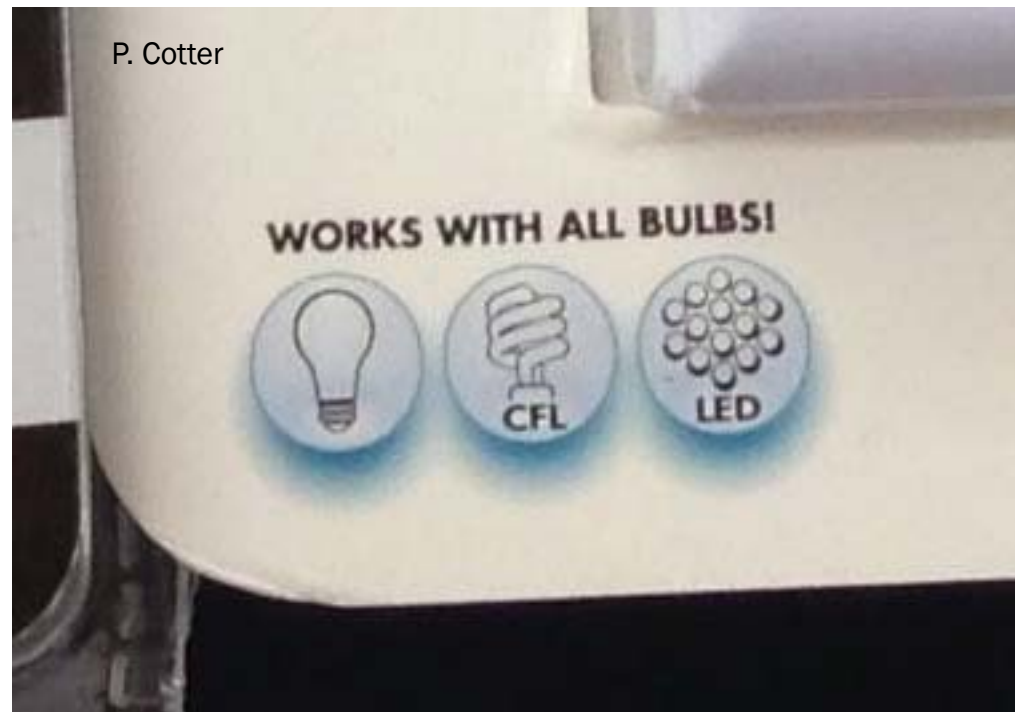

Look for
this or
similar
icon.

Or buy a control specifically made for your bulb type



P. Cotter

Energy Star-rated appliances

- Save Energy
- Save Money
- Are easy to find
 - Look for the sticker

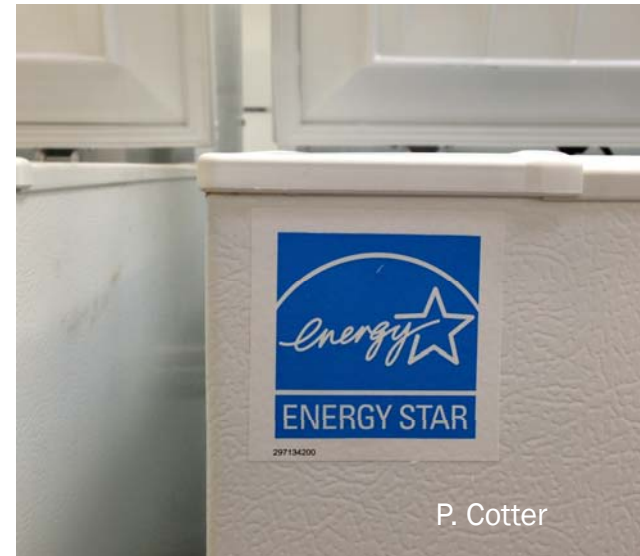

Energy Star-rated appliances

- Ventilation Fans
- Dishwashers
- Clothes washers
- Freezers
- Refrigerators
- Computers
- Electronics
- Others

Look for the Sticker!



Most newer appliances are more efficient

- More insulation
- Pump/compressor efficiency
- Fan efficiency
- “Sleep” modes



Refrigerator

- Check Fridge Temperature 36-38 degrees
 - Vacuum the coils
 - Pull away from wall/remove bottom panel
 - Use hose to vacuum around coils
 - Repeat every six months
 - Energy Star model will be 15% more energy efficient than regular models.
-

4

add photo

James Diemer, 2/19/2014

Freezer maintenance

- Defrost
- Keep it full
- Locate in cool area



Heating systems

- Professional Service
 - Change filters on furnaces every 6 months
 - Heating accounts for 65-77% of your home's energy usage.
 - Check your heat distribution
 - Look for ENERGY STAR.
-

7

photo in ACHP PP ours?

James Diemer, 2/19/2014

Water heater

- Turn down from 140 to 120 and save 6-10% on energy bill.
- Fix leaky faucets and running toilets.



Dryer

- Empty lint screen



Washing Machine

- Cold water
- Cold water detergent



Dishwasher

- “Eco” setting
- No heat dry



The Research Information Center (RIC)

- Resources -

Information on Energy-Efficiency

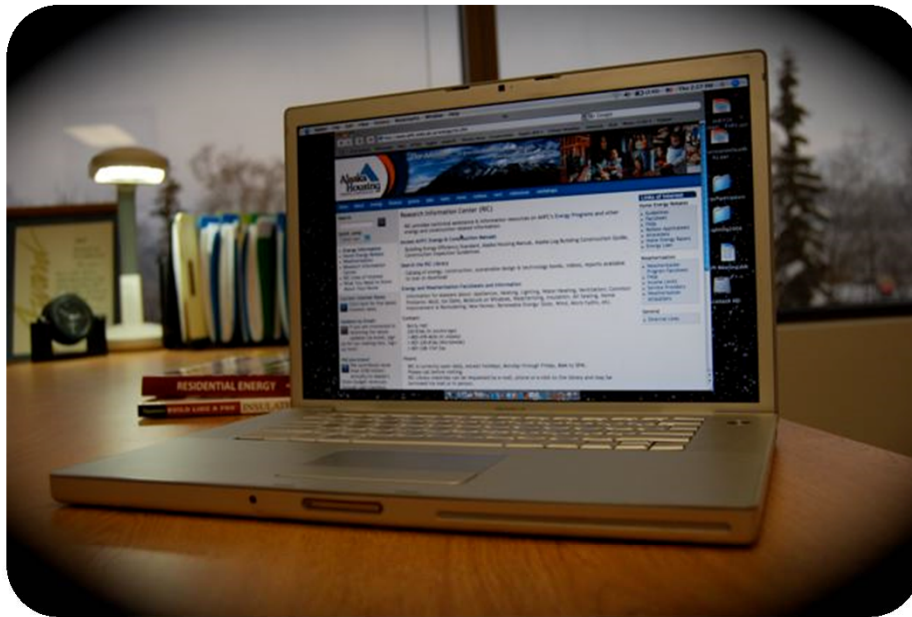

Good information makes for good decisions.
It's up to you!

Go online and search the library of
information:

AHFC Research Information Center

<http://www.ahfc.us/energy/ric.cfm>

Call 1-800-478-4636

or 1-907-330-8166

8AM-5PM, Monday-Friday,

except holidays

Appointment Recommended

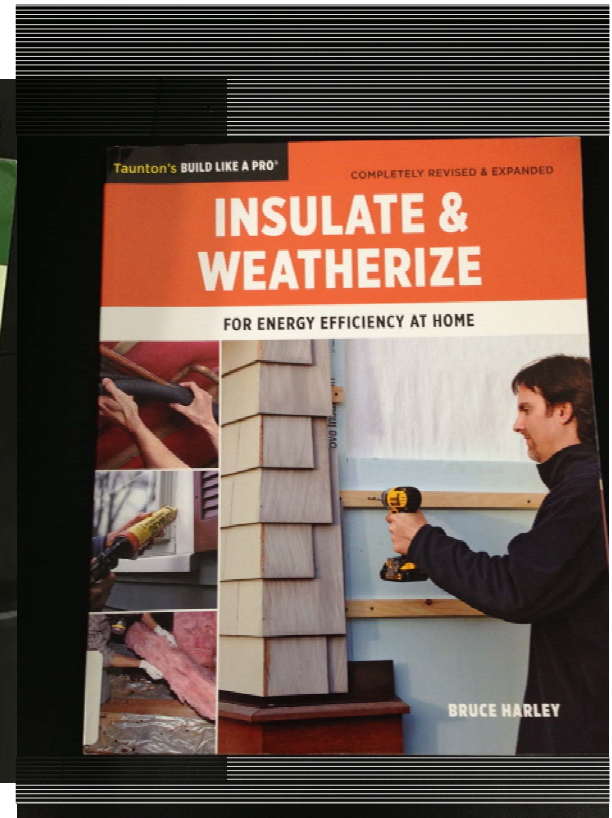
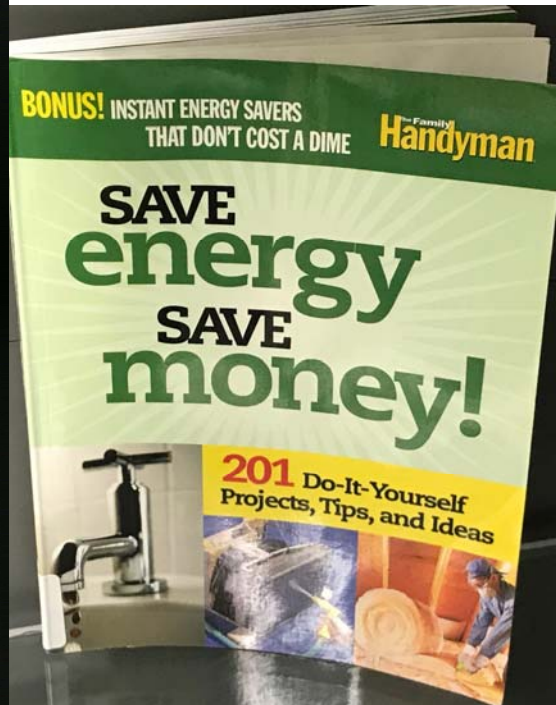

Research Information Center (RIC) Library

Welcome to AHFC's Research Information Center (RIC). The RIC is a building science library with informational materials for the building professional as well as the homeowner or "do-it-yourselfer". There are books on remodeling, energy efficiency, the environment, building components, building codes, commercial building, Alaska Statutes and much more.

Energy Information Specialist, Betty Hall, will be happy to provide technical assistance on AHFC's energy programs along with other energy and construction related information available through the library. The RIC houses over 9,000 books, manuals, magazines, visual/audio materials and internet links. Materials may be check out in person or mailed.



[RIC Library](#)

When you click the link, you will be able to search the available books and materials by typing in a subject, title, author, or catalog number. To search an online topic, type in the subject, followed by the word web (i.e. windows web). It will then provide a list of links for the information available online through the library.

The RIC is open from 8 am to 5 pm, Monday through Friday and closed on holidays. Appointments recommended.

CONTACT: FOR QUESTIONS AND APPOINTMENTS, CALL

Betty Hall
(907)330-8166 (Anchorage)
(800)478-4636 (statewide)
bhall@ahfc.us

AHFC

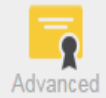

All Words

windows web | X

Sort: Title



Clear

Alaska Housing Finance Corporation *RIC Library Catalog*

Google

Return to: [AHFC Research Information Center homepage](#)

Resources

- AHFC - Research Information Center – 330-8166
Outside of Anchorage (800)478-4636
<https://www.ahfc.us/efficiency/research-information-center/>
 - AHFC Consumer Classes – Check class schedule at www.ahfc.us
 - Cold Climate Housing Research Center in Fairbanks
www.cchrc.org
 - Energy Star - For products, information, energy calculators, energy-saving tips
 - www.energystar.gov
-

AHFC's Energy Programs

AHFC Energy Efficiency Programs:

- Weatherization Program
- In Anchorage call Rural Cap 279-2511
- Second Mortgage for Energy Conservation
- Energy Efficiency Rate Reduction Mortgage
- www.ahfc.us

Weatherization Program

Individuals who meet income guidelines may apply for the Weatherization Program through the Weatherization provider in their area.

Anchorage Area

RurAL CAP

www.ruralcap.com 907-279-2511

Cook Inlet Housing Authority

www.cookinlethousing.org 907-793-3000

Mat-Su, Copper River, Kenai Peninsula, Prince William Sound

Alaska Community Development Corp

www.alaskaacdc.org 907-746-5680

Fairbanks Area

Interior Weatherization

www.interiorwx.org 907-452-5323

Tanana Chiefs Conference

www.tananachiefs.org

Juneau

RurAL CAP

www.ruralcap.com 907-279-2511

For more information and a complete list of WX providers visit:
www.ahfc.us/efficiency/energy-programs/weatherization/

FY 2017 INCOME LIMITS FOR ALASKA

Effective
April 1,
2017

Community Name	INCOME LIMIT - 1 PERSON	INCOME LIMIT - 2 PERSONS	INCOME LIMIT - 3 PERSONS	INCOME LIMIT - 4 PERSONS	INCOME LIMIT - 5 PERSONS	INCOME LIMIT - 6 PERSONS	INCOME LIMIT - 7 PERSONS	INCOME LIMIT - 8 PERSONS	EA ADDED FAMILY MEMBER
Anchorage Municipality Low Income Limit	62,300	71,200	80,100	89,000	96,120	103,240	110,360	117,480	7,120
Aleutians East Borough Low Income Limit	59,430	67,920	76,410	84,900	91,692	98,484	105,276	112,068	6,792
Aleutians West Census Low Income Limit	63,140	72,160	81,180	90,200	97,416	104,632	111,848	119,064	7,216
Bethel Census Area Low Income Limit	59,430	67,920	76,410	84,900	91,692	98,484	105,276	112,068	6,792
Bristol Bay Borough Low Income Limit	66,500	76,000	85,500	95,000	102,600	110,200	117,800	125,400	7,600
Denali Borough Low Income Limit	74,060	84,640	95,220	105,800	114,264	122,728	131,192	139,656	8,464
Dillingham Census Area Low Income Limit	59,430	67,920	76,410	84,900	91,692	98,484	105,276	112,068	6,792
Fairbanks North Star Borough Low Income Limit	59,430	67,920	76,410	84,900	91,692	98,484	105,276	112,068	7,504
Haines Borough Low Income Limit	59,430	67,920	76,410	84,900	91,692	98,484	105,276	112,068	6,792
Hoonah-Angoon Census Area Low Income Limit	59,430	67,920	76,410	84,900	91,692	98,484	105,276	112,068	6,792
Juneau Borough Low Income Limit	71,050	81,200	91,350	101,500	109,620	117,740	125,860	133,980	8,120
Kenai Peninsula Borough Low Income Limit	59,430	67,920	76,410	84,900	91,692	98,484	105,276	112,068	6,792
Ketchikan Gateway Borough Low Income Limit	61,180	69,920	78,660	87,400	94,392	101,384	108,376	115,368	6,992
Kodiak Island Borough Low Income Limit	59,430	67,920	76,410	84,900	91,692	98,484	105,276	112,068	6,792
Lake and Peninsula Borough Low Income Limit	59,430	67,920	76,410	84,900	91,692	98,484	105,276	112,068	6,792
Matanuska-Susitna Borough Low Income Limit	63,280	72,320	81,360	90,400	97,632	104,864	112,096	119,328	7,232
Nome Census Area Low Income Limit	59,430	67,920	76,410	84,900	91,692	98,484	105,276	112,068	6,792
North Slope Borough Low Income Limit	60,060	68,640	77,220	85,800	92,664	99,528	106,392	113,256	6,864
Northwest Arctic Borough Low Income Limit	59,430	67,920	76,410	84,900	91,692	98,484	105,276	112,068	6,792
Petersburg Census Area Low Income Limit	61,250	70,000	78,750	87,500	94,500	101,500	108,500	115,500	7,000
Prince of Wales-Hyder Census Low Income Limit	59,430	67,920	76,410	84,900	91,692	98,484	105,276	112,068	6,792
Sitka City & Borough Low Income Limit	59,430	67,920	76,410	84,900	91,692	98,484	105,276	112,068	6,792
Skagway Municipality Low Income Limit	60,900	69,600	78,300	87,000	93,960	100,920	107,880	114,840	6,960
Southeast Fairbanks Census Area Low Income Limit	59,430	67,920	76,410	84,900	91,692	98,484	105,276	112,068	6,792
Valdez-Cordova Census Low Income Limit	70,630	80,720	90,810	100,900	108,972	117,044	125,116	133,188	8,072
Wade Hampton Census Area Low Income Limit	59,430	67,920	76,410	84,900	91,692	98,484	105,276	112,068	6,792
Wrangell City and Borough Census Area Low Income Limit	59,430	67,920	76,410	84,900	91,692	98,484	105,276	112,068	6,792
Yakutat City & Borough Low Income Limit	59,430	67,920	76,410	84,900	91,692	98,484	105,276	112,068	6,792
Yukon-Koyukuk Census Area Low Income Limit	59,430	67,920	76,410	84,900	91,692	98,484	105,276	112,068	6,792
2017 DOE Poverty Income Levels-FINAL	30,120	40,580	51,040	61,500	71,960	82,420	92,880	103,340	10,460

Second Mortgage for Energy Conservation

- Homeowners may finance up to \$30,000 of energy efficient improvements
- Choose from a list of upgrades included on your home energy rating
- The maximum loan term is 15 years
- For forms and instructions visit our website: http://www.ahfc.us/loans/second_energy_conserv.cfm

- Contact to apply:**

Alaska USA Federal Credit Union
Real Estate Telephone Loan Center (RETLIC)
907-786-2800 (toll free 1-888-425-9813)
PO Box 196613
Anchorage, AK 99519-6613

The Energy Efficiency Interest Rate Reduction Program – EEIRR Loan Add On

Interest rate reductions apply to the first \$200,000 of the loan amount. A loan amount exceeding \$200,000 receives a blended rate rounded up to the next 0.125 percent.

New Construction

ACCESS TO NATURAL GAS

- 5 Star Plus Rating: -0.250 percent
- 6 Star Rating: -0.375 percent

NO ACCESS TO NATURAL GAS

- 5 Star Plus Rating: -0.375 percent
 - 6 Star Rating: -0.500 percent
-

The Energy Efficiency Interest Rate Reduction Program – EEIRR Loan Add On

Existing Properties with Energy Improvements

ACCESS TO NATURAL GAS

1 Step: -0.125 percent
2 Steps: -0.250 percent
3 Steps: -0.500 percent
4 Steps: -0.625 percent

NO ACCESS TO NATURAL GAS

1 Step: -0.250 percent
2 Steps: -0.375 percent
3 Steps: -0.625 percent
4 Steps: -0.750 percent

EEIRR Documents Checklist



- Must sign a UND-10 Form with Lender – only available with AHFC Loans
 - Both the “As-Is” & “Final” rating must be completed within 365 days of closing
 - Ratings must be submitted to Lender no later than 30 days after this date.
 - Lender may require receipts for work done.
 - Interest rate will be modified when received by AHFC from Lender.
-

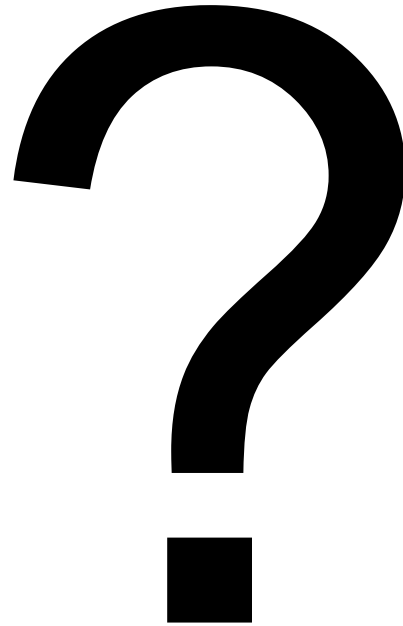

Thank you for joining me today!

Betty Hall – Research Information Center

In Anchorage 907-330-8166

Toll free 800-478-4636

bhall@ahfc.us

www.ahfc.us